

TECHNISCHE
UNIVERSITÄT
DARMSTADT

SIMULATION STUDY OF NANOSTRUCTURED PLASMONIC COPPER PHOTOCATHODES

Margarita Bulgacheva¹, Erion Gjonaj¹, Dmitry Bazyl²

¹ TEMF, Technische Universität Darmstadt, Darmstadt, Germany

² Deutsches Elektronen-Synchrotron, Hamburg, Germany

INTRODUCTION

- A Continuous Wave (**CW**) **electron source** is necessary for the future operation of the CW and High-Duty-Cycle EuXFEL.
- DESY is currently developing a 1.6-cell **SRF gun cavity**, designed to operate at 1.3 GHz.
- This gun can only be used with **metal photocathodes** due to construction (no load lock system).
- It is necessary to design a **copper photocathode with increased Quantum Efficiency (QE)**.

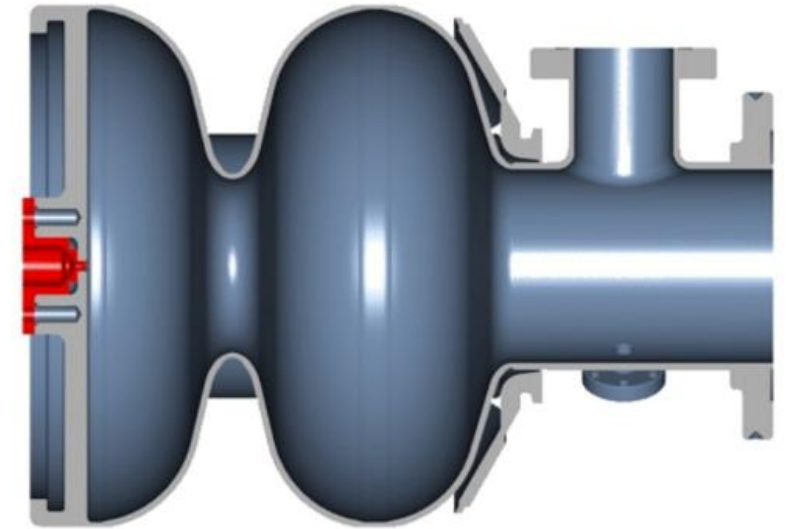

BASIC IDEA OF PLASMON ENHANCED PHOTOEMISSION

Periodic structure

+

Laser pulse



Surface Plasmon
Polariton (SPP) modes



Increased local
absorption

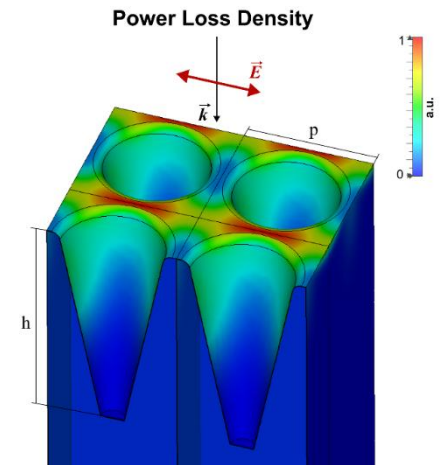
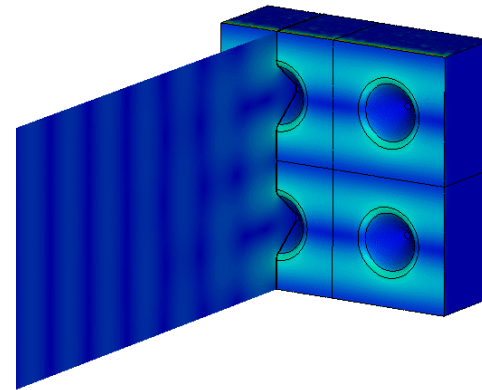
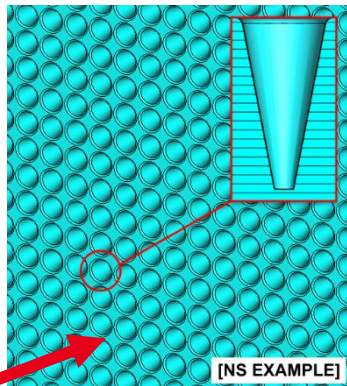

Increased quantum efficiency (QE)

SIMULATION PROCESS

- **Electromagnetic simulation**
- Photoemission model
- Beam dynamics

ELECTROMAGNETIC SIMULATION

- Excitation: **linearly polarized** plane wave
- Target laser wavelength: **257 nm (UV)**
- Optimization goal: **minimize reflectance** at the target laser wavelength

Geometry: **conical nanostructure**, periodicity = 220 nm, depth = 360 nm

Reflectance is decreased from 36% to 6%

Broadband reflectance spectra compared to the flat copper surface in UV

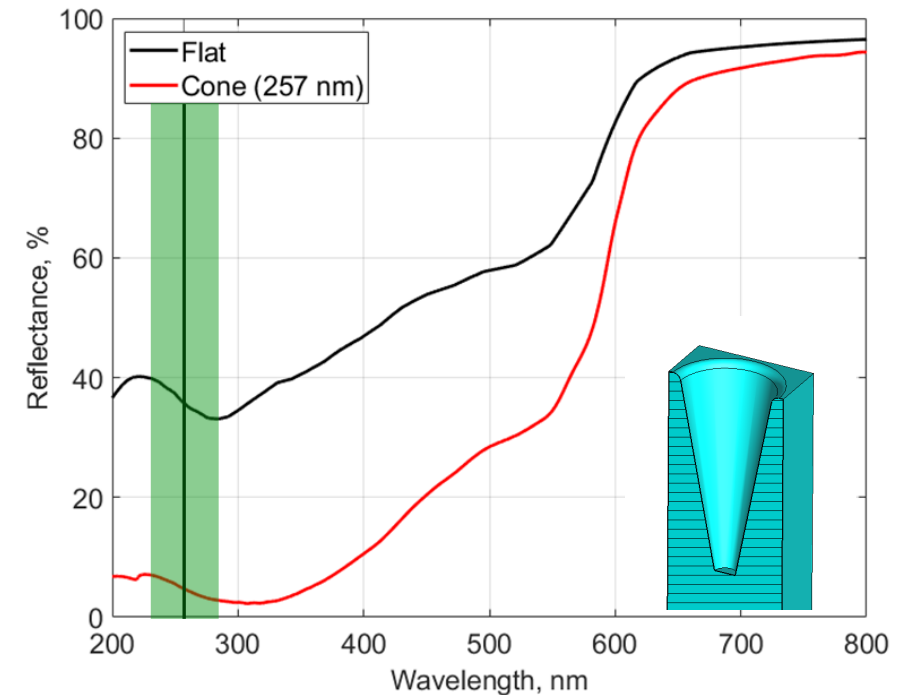

SIMULATION PROCESS

- Electromagnetic simulation
 - Plane wave excitation
 - Geometry optimization
 - Export power losses in volume
- **Photoemission model** ←
- Beam dynamics

PHOTOEMISSION MODEL

THEORY OVERVIEW

- **Process:** Absorption of photons excites electrons → electron emission from the surface

1. **Optical absorption** in the metal
2. **Electron transport** to the surface (scattering, losses)
3. **Escape** over the surface potential barrier

- **Fowler–DuBridge formulation**

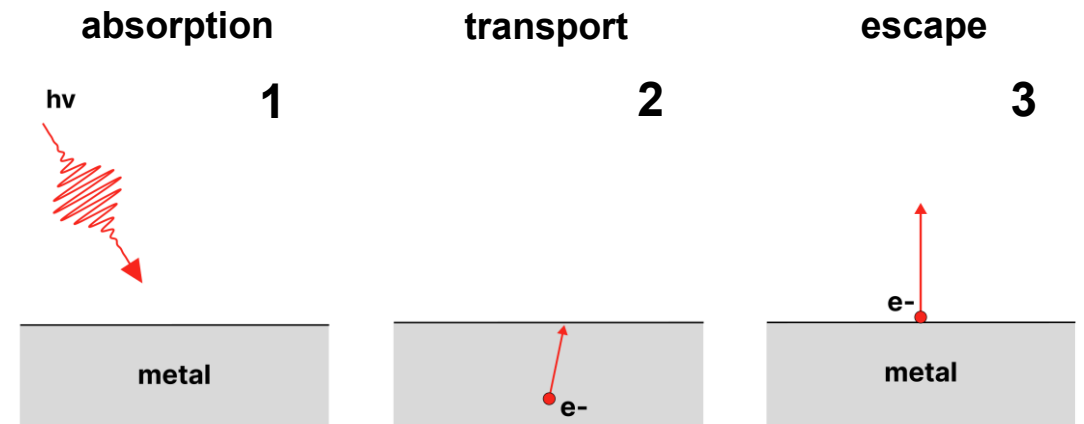

$$J_e(\mathbf{r}, \omega) = A \frac{e}{\hbar\omega} [1 - R(\mathbf{r}, \omega)] I_\lambda T^2 F\left(\frac{\hbar\omega - e\Phi(\mathbf{r})}{kT}\right)$$

PHOTOEMISSION MODEL

EMISSION SAMPLES

- **Emission points** are located in the facet centers
- The electron **kinetic energy** is distributed in the range

$$0 \leq E_{electron} \leq h\omega - \phi_{eff}$$
- **Angle distribution** is customizable (here: Lambert distribution)
- Electrons are emitted randomly from part of the emission points
- **Macroparticle charges** can be computed from Fowler-Dubridge or normalized to the total bunch charge

Every timestep 1 macroparticle per N emission points with normalized charge is emitted with randomized angle, energy and time between [t; t+Δt]

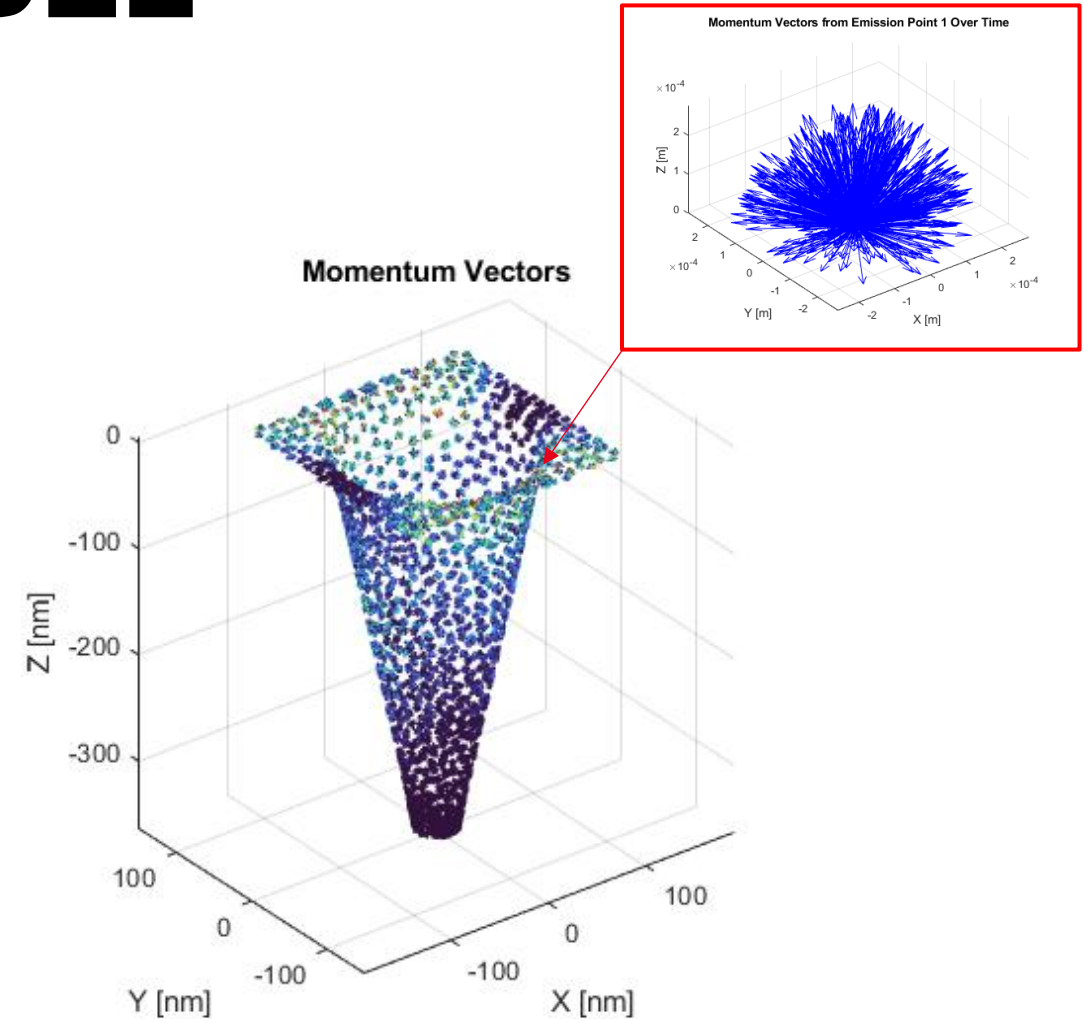

SIMULATION PROCESS

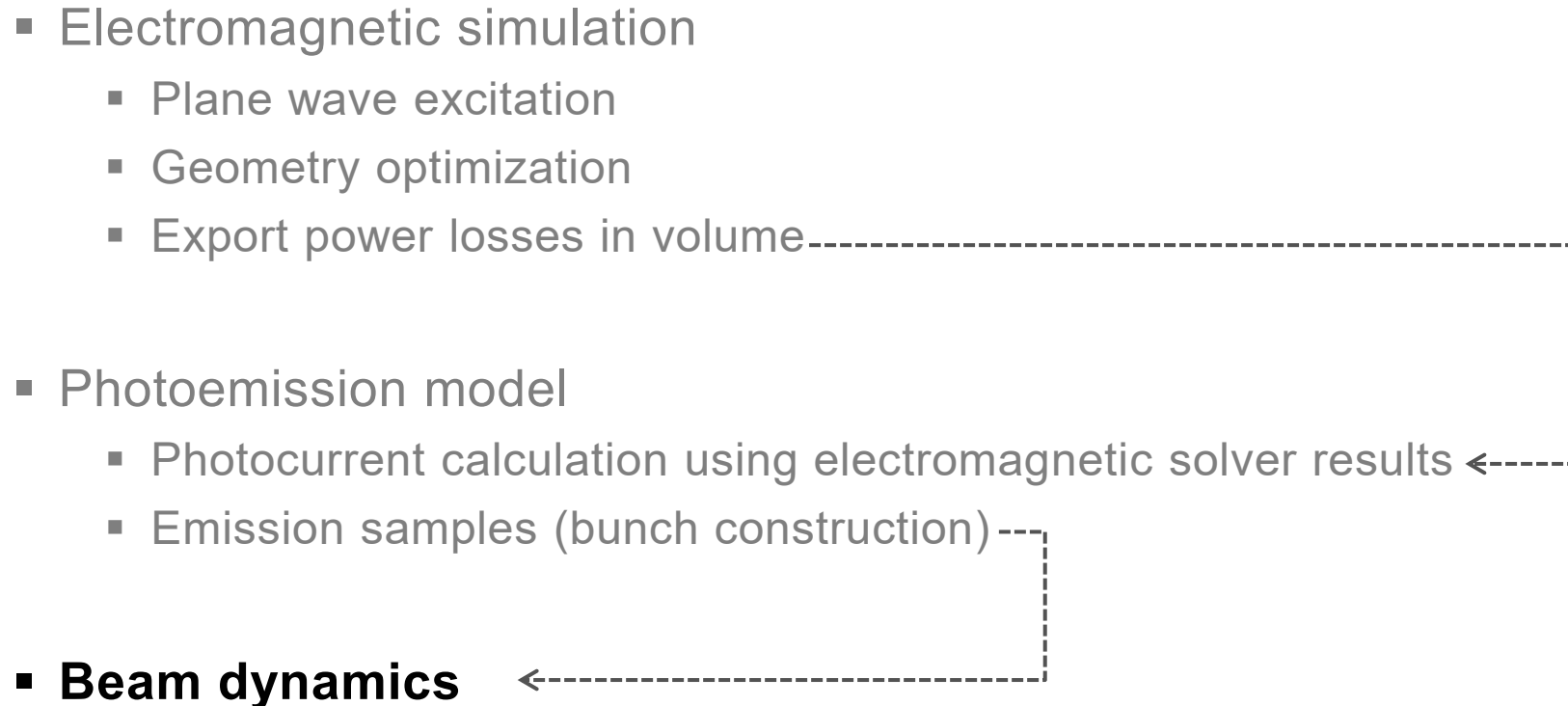
- Electromagnetic simulation
 - Plane wave excitation
 - Geometry optimization
 - Export power losses in volume
 - Photoemission model
 - Photocurrent calculation using electromagnetic solver results
 - Emission samples (bunch construction)
 - **Beam dynamics**
- 

BEAM DYNAMICS

1. How does **cathode geometry** influence beam properties?
2. How does the **Schottky effect** influence beam properties?
3. How does **space charge** influence beam properties?
4. Scale-up model to **macroscopic scale**:
 1. How many nanoholes are needed to define a **representative emission area**?
 2. How does the particle distribution change with **distance** from the cathode?

Final goal: real size cathode in full electron gun simulation

SINGLE NANO HOLE

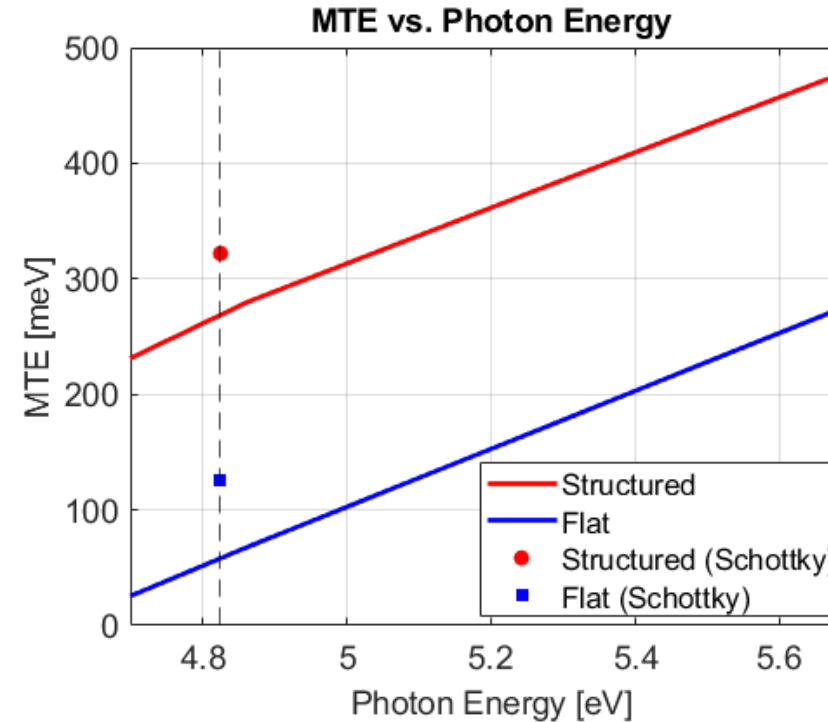
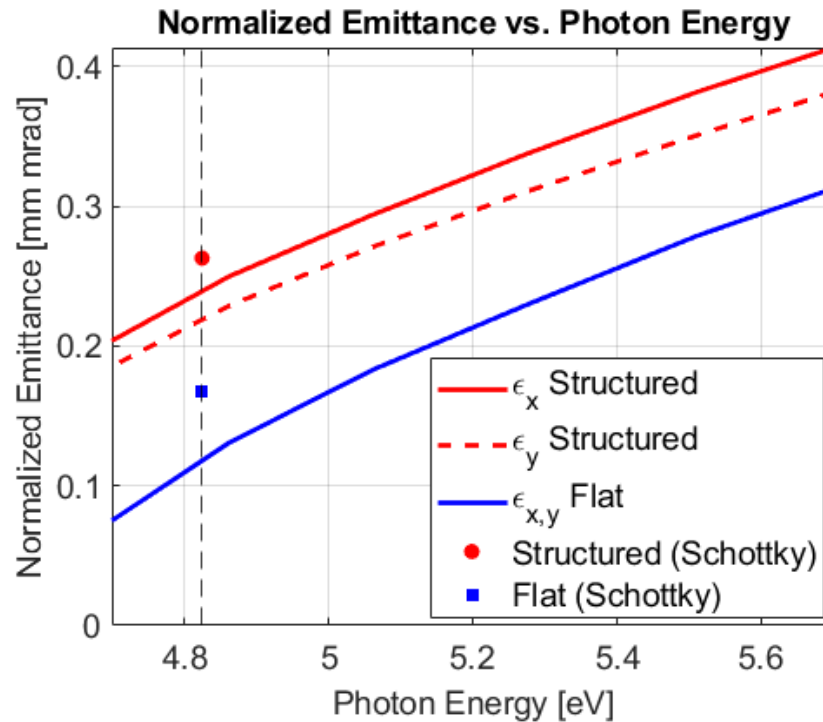

Target photon energy = 4.82 eV ($\lambda_{\text{target}} = 257 \text{ nm}$)

Scaling parameters:

Total charge = 100 pC; Pulse width = 8 ps; Repetition rate = 1 MHz;
RMS laser spotsize = 0.25 mm

SINGLE NANO HOLE TRANSVERSAL

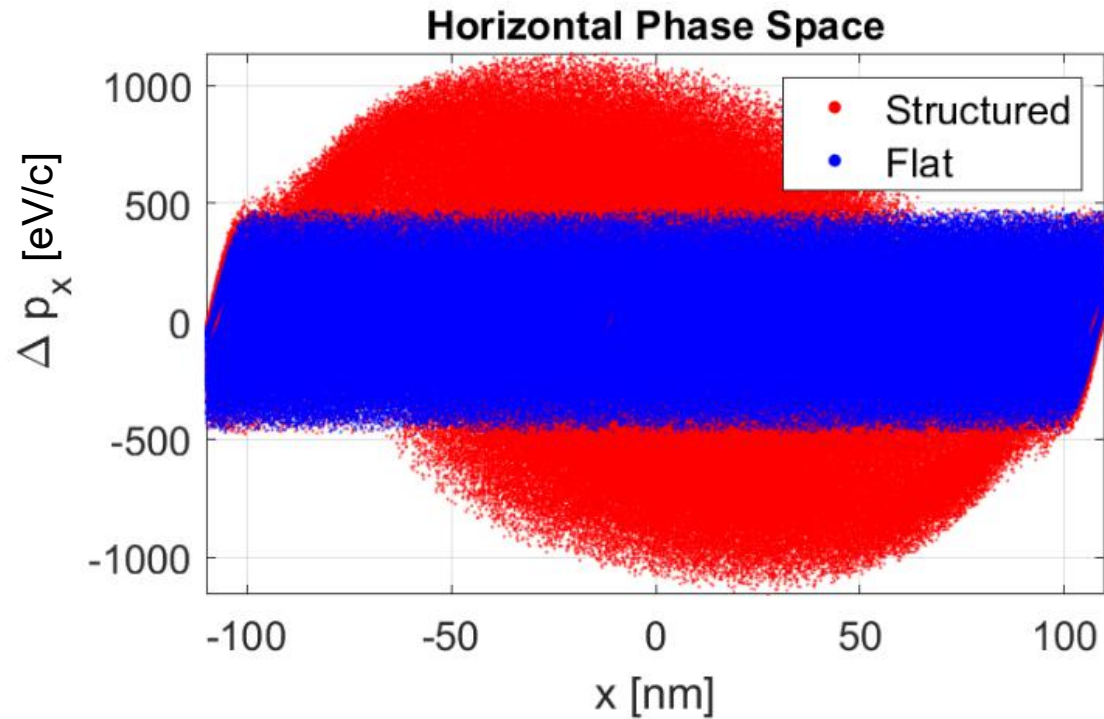

The **asymmetry** in the transverse plane is due to **particles emitted from inclined cathode areas** facing towards the interior of the nanohole.

SINGLE NANO HOLE LONGITUDINAL

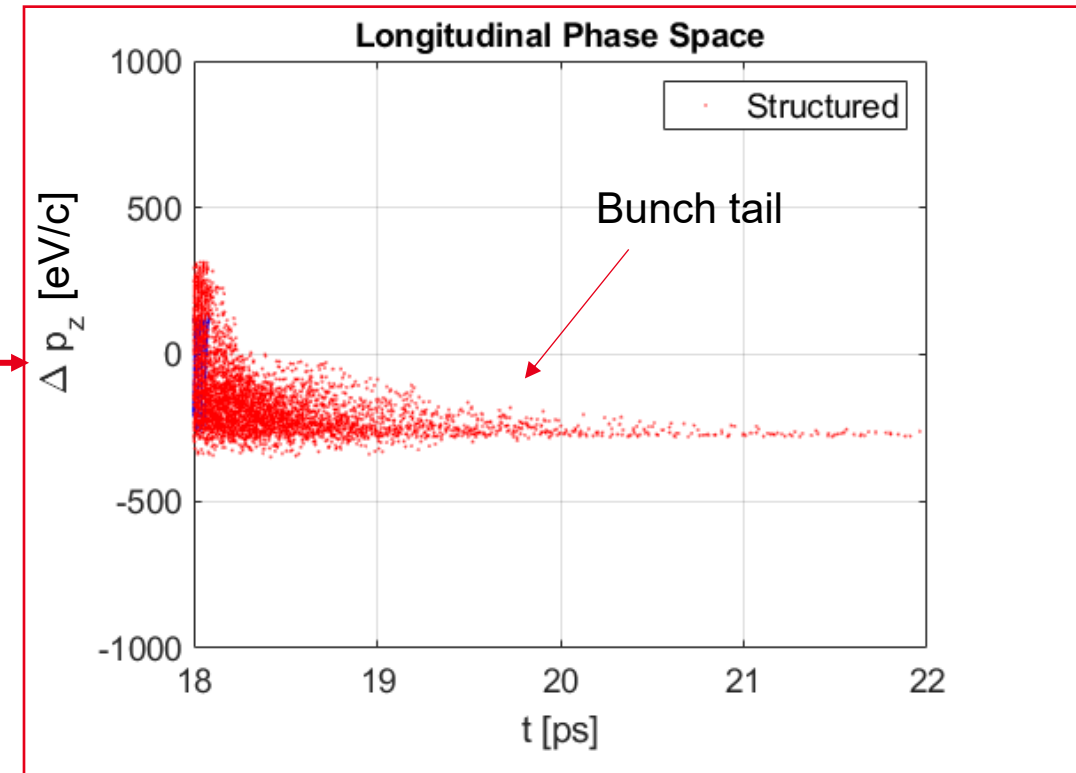
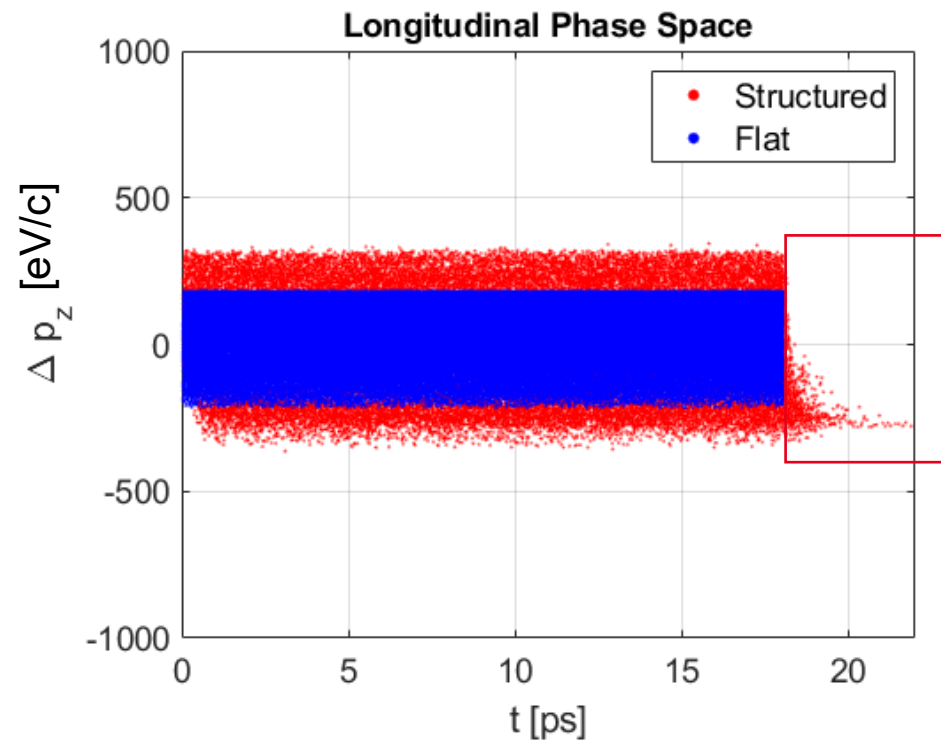

The electrons emitted from the **cone depth** are **less accelerated** by the cavity field, which causes energy spread growth and longitudinal phase-space bending at the bunch tail.

SINGLE NANO HOLE LONGITUDINAL

Flat

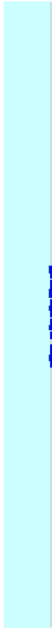

Structured

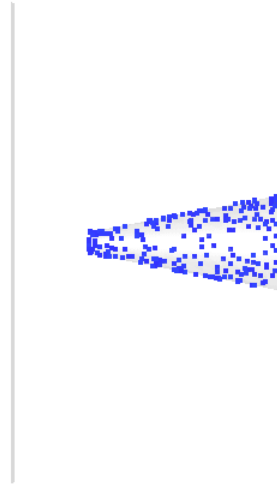

$E_{acc} = 40 \text{ MV/m}$

SPACE CHARGE EFFECT

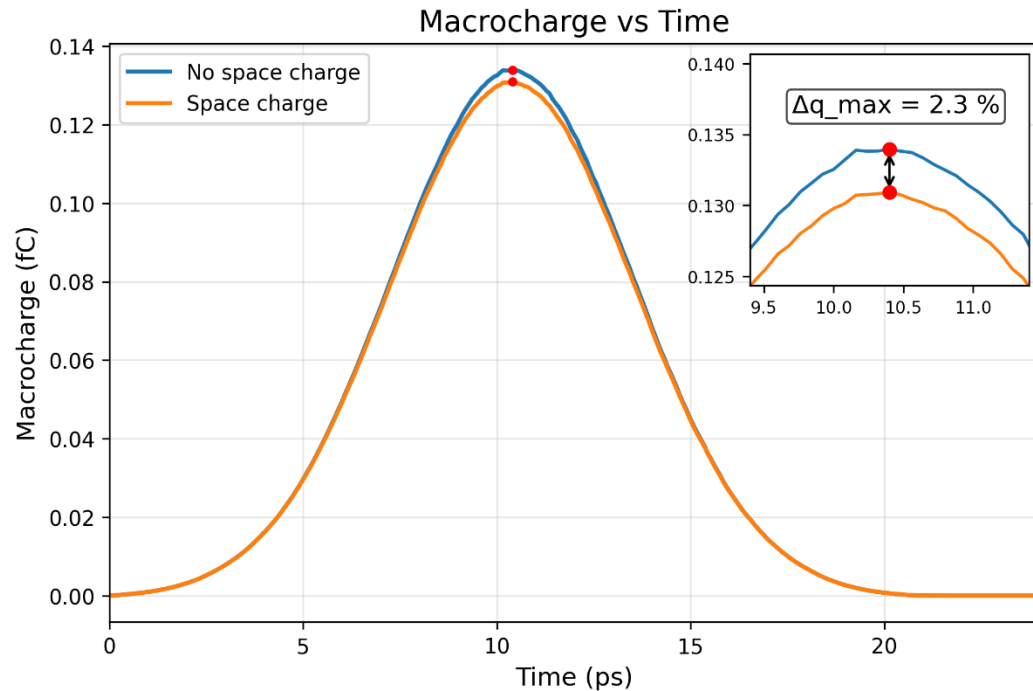

Total charge emitted from the whole cathode = 100 pC

- Emitted charge follows the incident Gaussian time distribution
- The total charge is reduced by $\sim 2\%$ ($Q_{\text{bunch}} = 100 \text{ pC}$)
- Some particles are lost inside of the cone due to space charge

Space charge density



SPACE CHARGE EFFECT EMITTANCE AND MTE

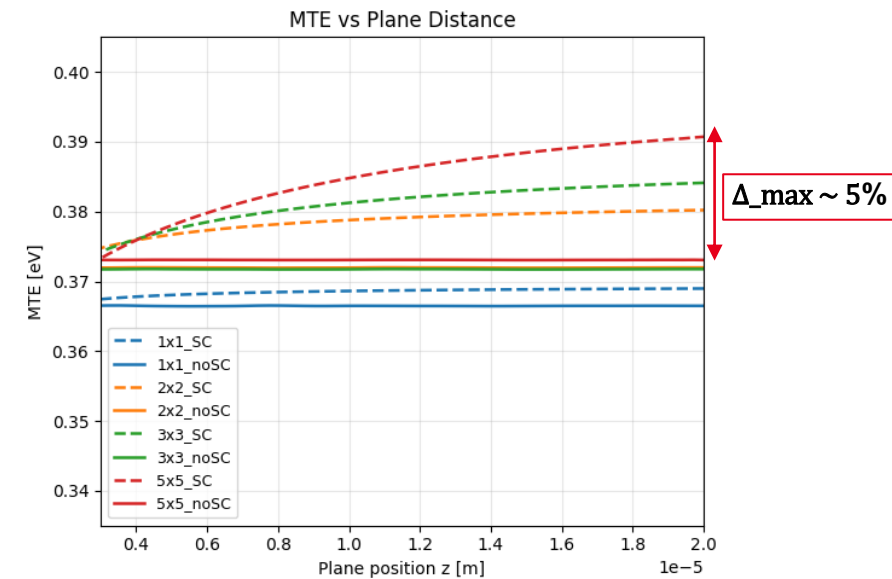
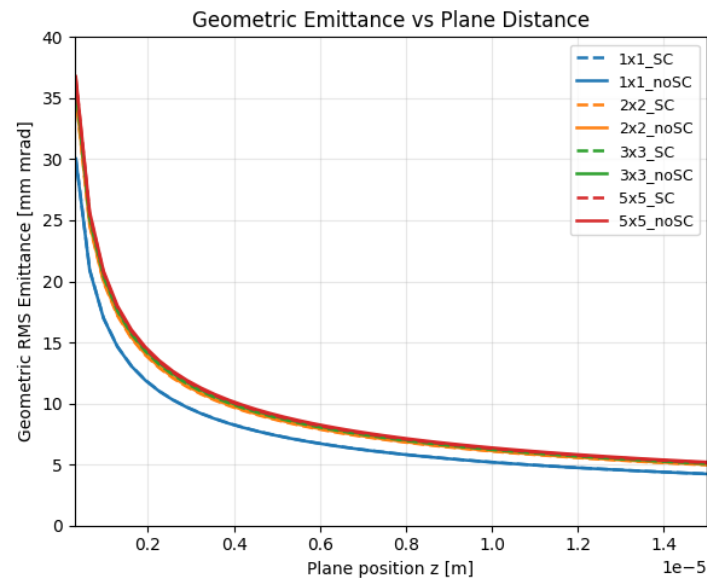
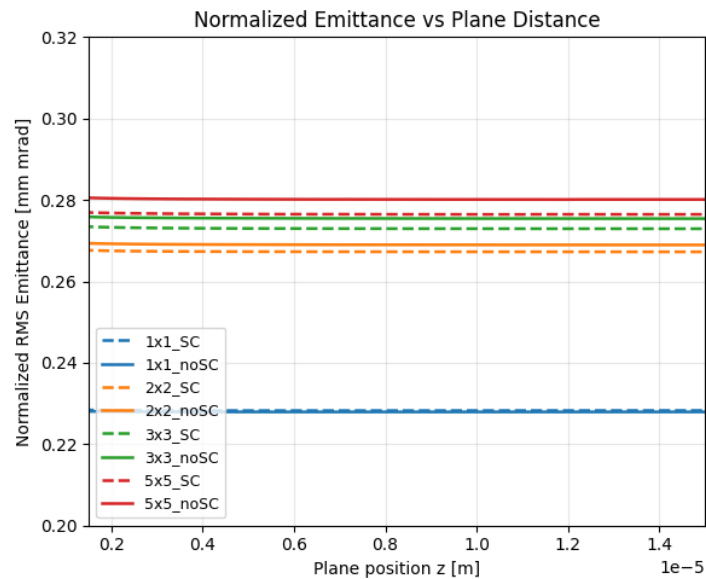

- Increasing the number of nanoholes demonstrates convergence
- Normalized emittance is slightly decreased due to space charge
- Geometric emittance converges with the distance from the cathode
- MTE increases due to space charge



SIMULATION PROCESS

- **Electromagnetic simulation**

- Plane wave excitation
- Geometry optimization
- Export power losses in volume

- **Photoemission model**

- Photocurrent calculation using electromagnetic solver results
- Emission samples (bunch construction)

- **Beam dynamics**

- PIC simulation
- Analysis

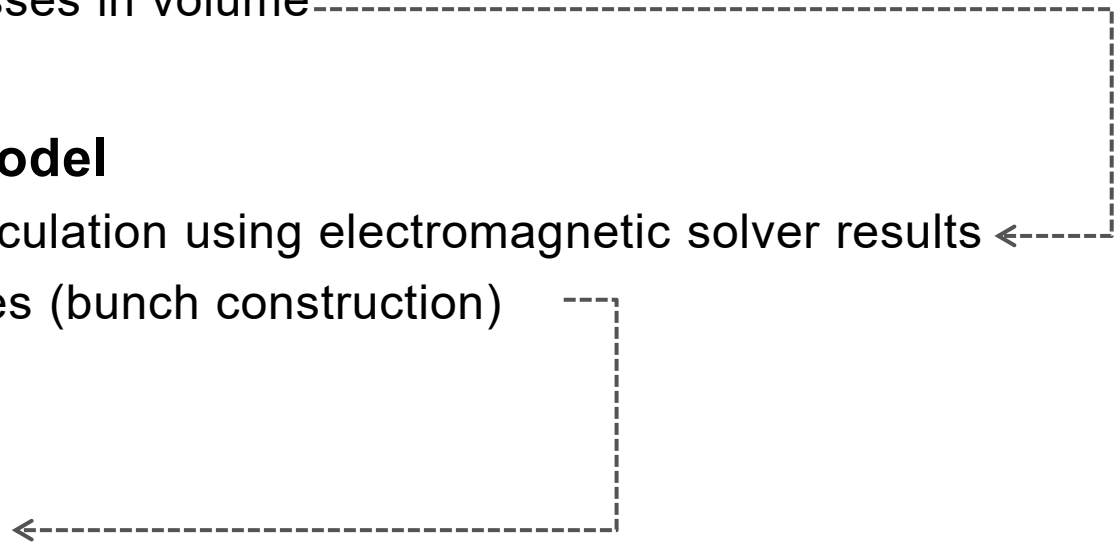

SIMULATION PROCESS

Single nanohole

- **Electromagnetic simulation**

- Plane wave excitation
- Geometry optimization
- Export power losses in volume

- **Photoemission model**

- Photocurrent calculation using electromagnetic solver results ←
- Emission samples (bunch construction)

- **Beam dynamics**

- PIC simulation ←
- Analysis

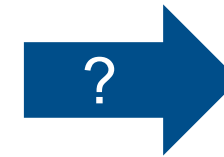

Full cathode

- “Flat” plane
- Full electron gun PIC simulation
- Beam dynamics in e-gun

TOWARDS REAL-SIZE CATHODE

~1e6 nanoholes

Single nanohole
220 x 220 nm

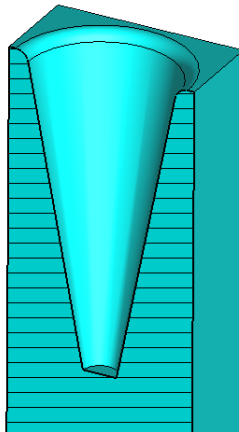

Extrapolation

Machine learning?

Full cathode
0.25 mm RMS

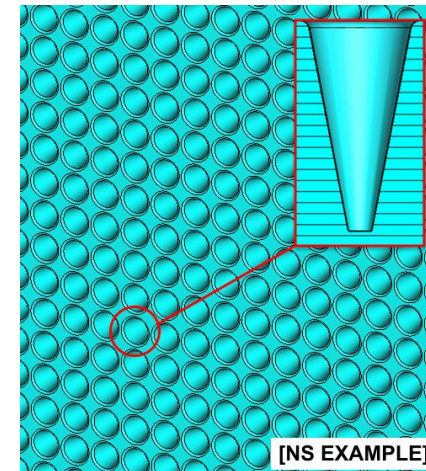

TOWARDS REAL-SIZE CATHODE

ML IMPLEMENTATION

First step: “learn” the distributions

- Normalizing flows + PyTorch
- During training, we transform a base distribution to match our target distribution
- This approach allows us to train the model in 6D

Normalizing Flows

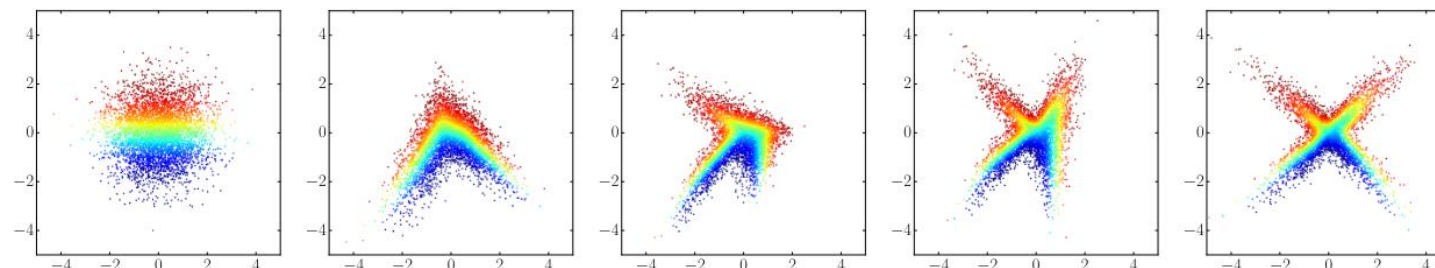
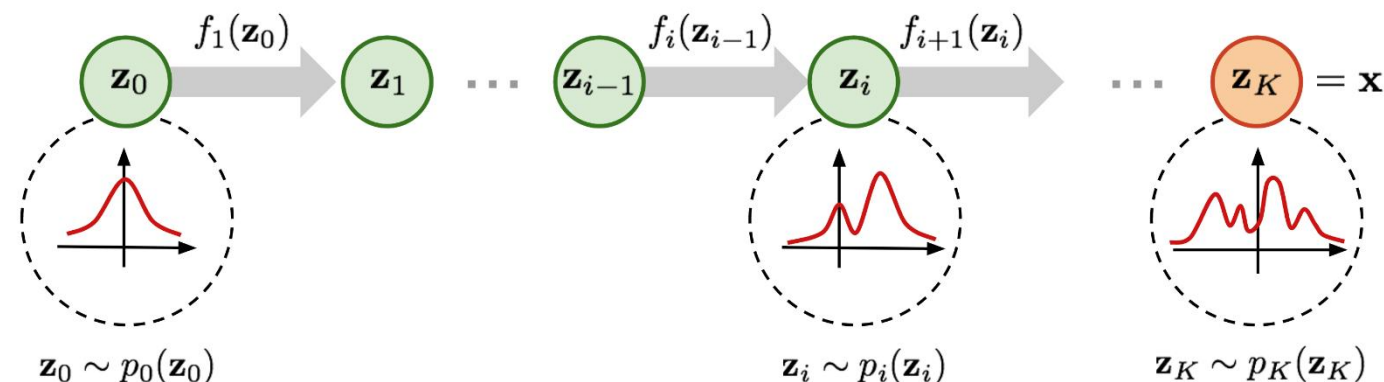
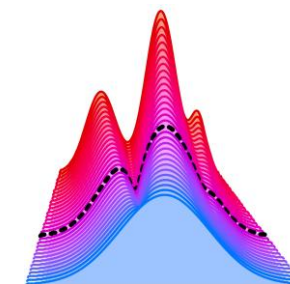

TOWARDS REAL-SIZE CATHODE ML IMPLEMENTATION

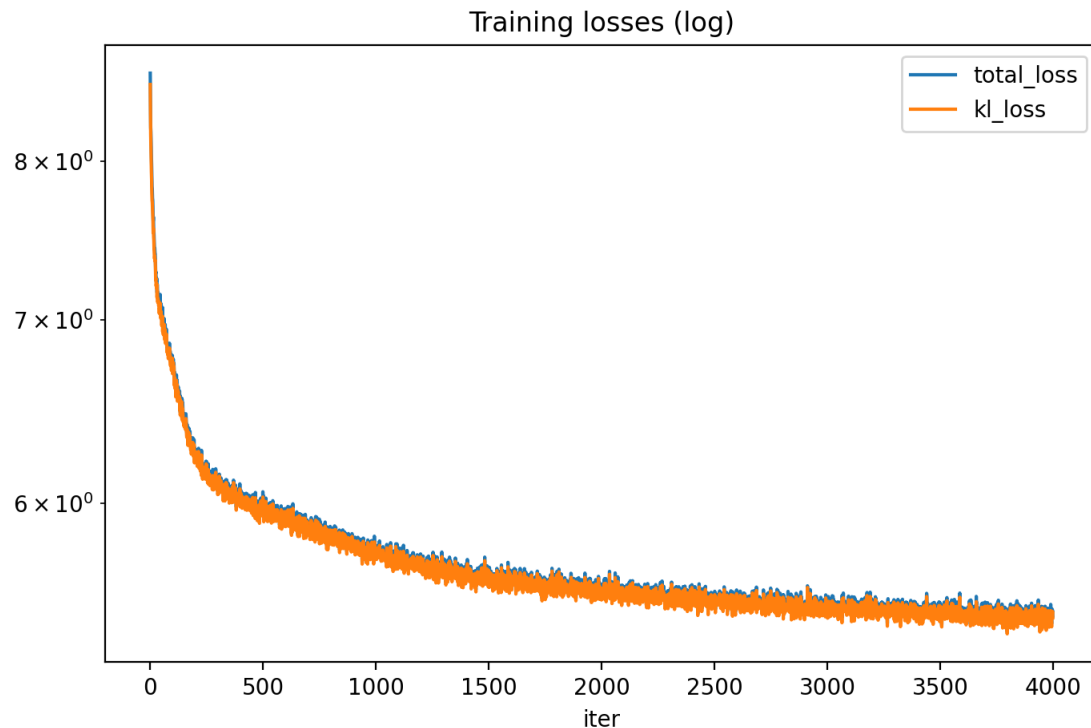

- **Loss function** is a quantitative measure of how far the model's predicted 6D particle distribution deviates from the target data.
- Loss function decreases as the **normalizing flow learns the structure of the data**.
- Early stages: **rapid drop** as the model captures coarse features of the distribution (density, correlations).
- Later stages: **slow convergence** as the model refines fine-scale structure (for example, tails).

TOWARDS REAL-SIZE CATHODE ML IMPLEMENTATION

Preliminary results [2x2 nanoholes]

First step: “learn” the distributions

Loss function:

Particle distribution + covariances + means

+ Additional constraints

	Original	Trained model	Difference
Emittance X	8.472e-11	8.408e-11	0.7%
Emittance Y	7.934e-11	8.101e-11	2%
MTE	2.018e-01	2.311e-01	14%

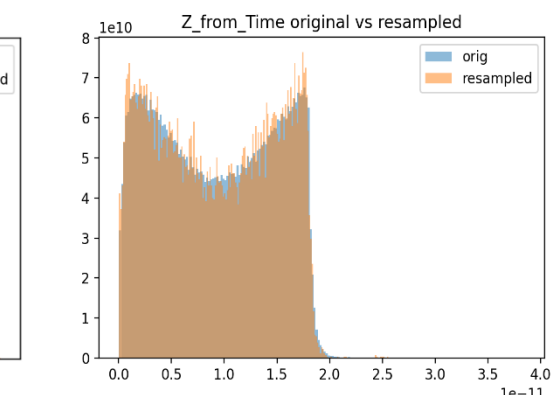
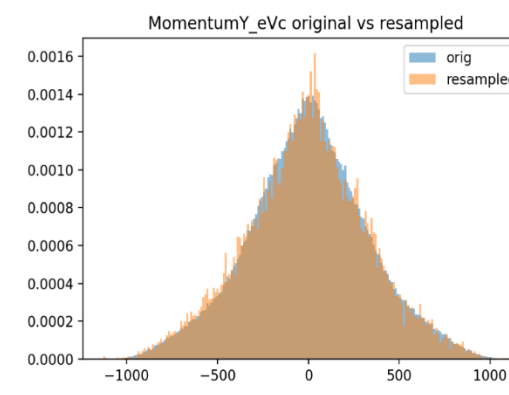
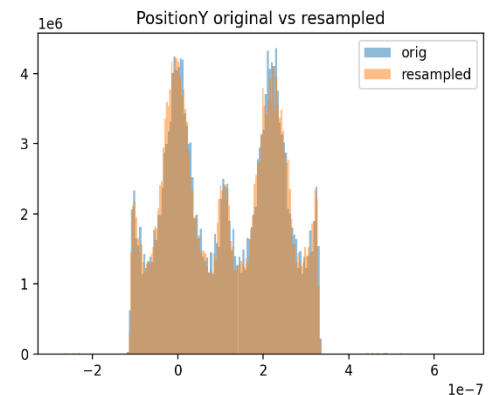
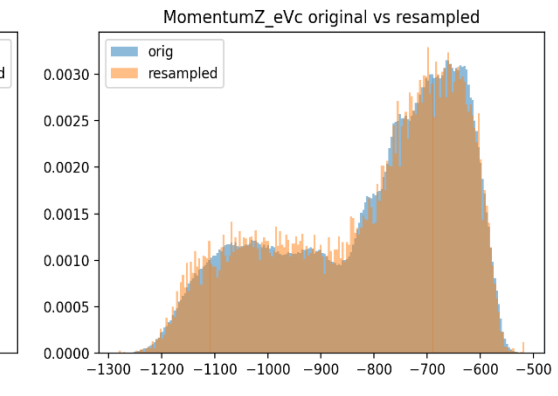
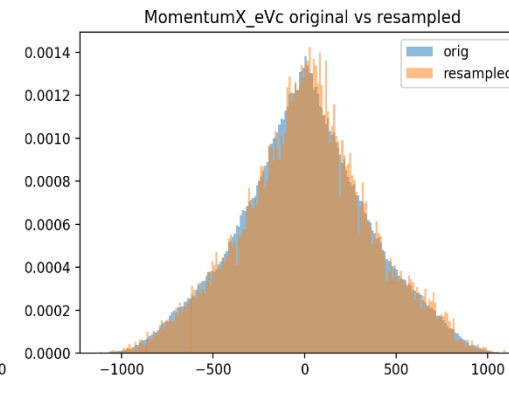
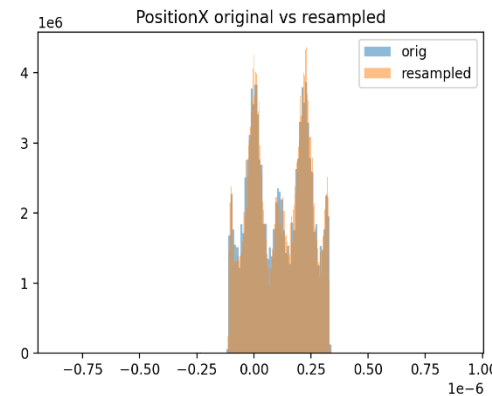



TOWARDS REAL-SIZE CATHODE ML IMPLEMENTATION

Preliminary results [2x2 nanoholes]

First step: “learn” the distributions

Loss function:

Particle distribution + covariances + means

+ Additional constraints

	Original	Trained model	Difference
Emittance X	8.472e-11	8.408e-11	0.7%
Emittance Y	7.934e-11	8.101e-11	2%
MTE	2.018e-01	2.311e-01	14%

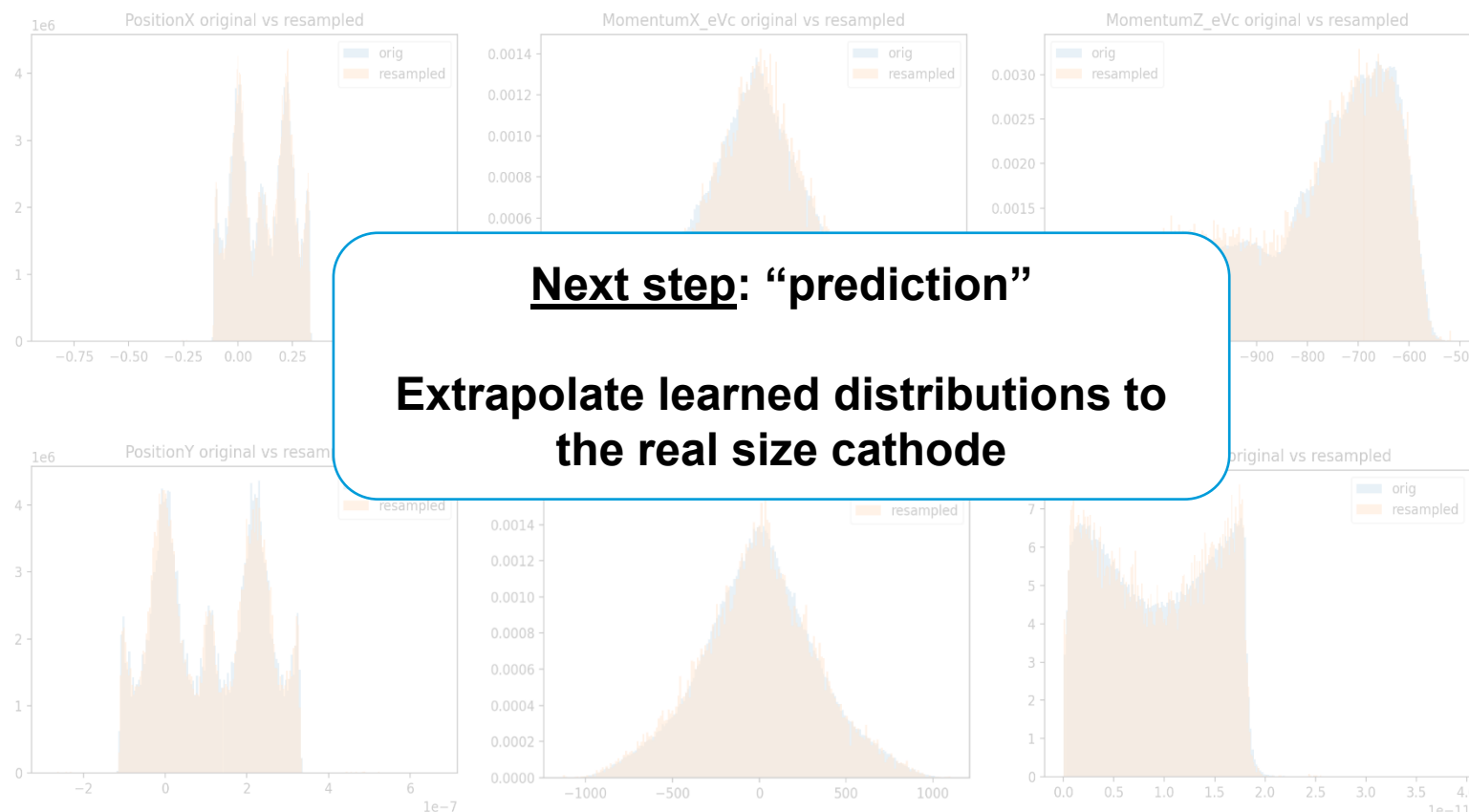

CONCLUSION

- **Electromagnetic simulation** of plasmonic cathodes:
 - Electric field and **absorptance enhancement** (~50%)
- **Photoemission model for nanostructured cathodes**
 - Based on **Fowler-Dubridge approach**
 - **Spatially resolved Schottky correction**: 0-0.3 eV
 - Applied the model to the case of the **DESY nanostructured cathodes** using a single-nanohole model
- **Beam dynamics simulation**:
 - **Single nanohole**: characterization of emitted beam properties — phase-space asymmetry, emittance increase compared to the flat cathode
 - **Space charge effect**: weak impact for $Q_{\text{bunch}} = 100 \text{ pC}$
 - Increasing the number of nanoholes demonstrates convergence

OUTLOOK

- Homogenization of beam distribution in front of the cathode
- Development of a **particle interface**
- Full electron gun tracking simulations
- Extend the approach for **multiphoton emission**
- Extend the approach for **semiconductor** case

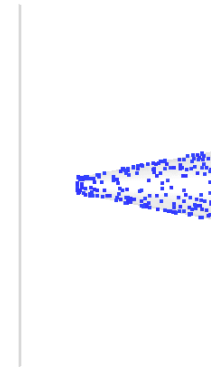

Additional applications: **surface roughness**, other nanostructures (gratings, spirals)