

# Trapped Mode Analysis of the New PETRA IV Collimators



Pascal Reinhart\*, Erion Gjonaj\*, Herbert De Gersem\*, Sergey Antipov+  
\*TEMF, Darmstadt, +DESY, Hamburg

## DESY-TEMF Workshop

December 11, 2025, DESY, Hamburg

# PETRA IV

- New hard X-ray source
- PETRA III shutdown in December 2029
- PETRA IV becomes operational in 2032

## Collimators

- 8 Collimators in total
  - 4 Vertical
  - 4 Horizontal

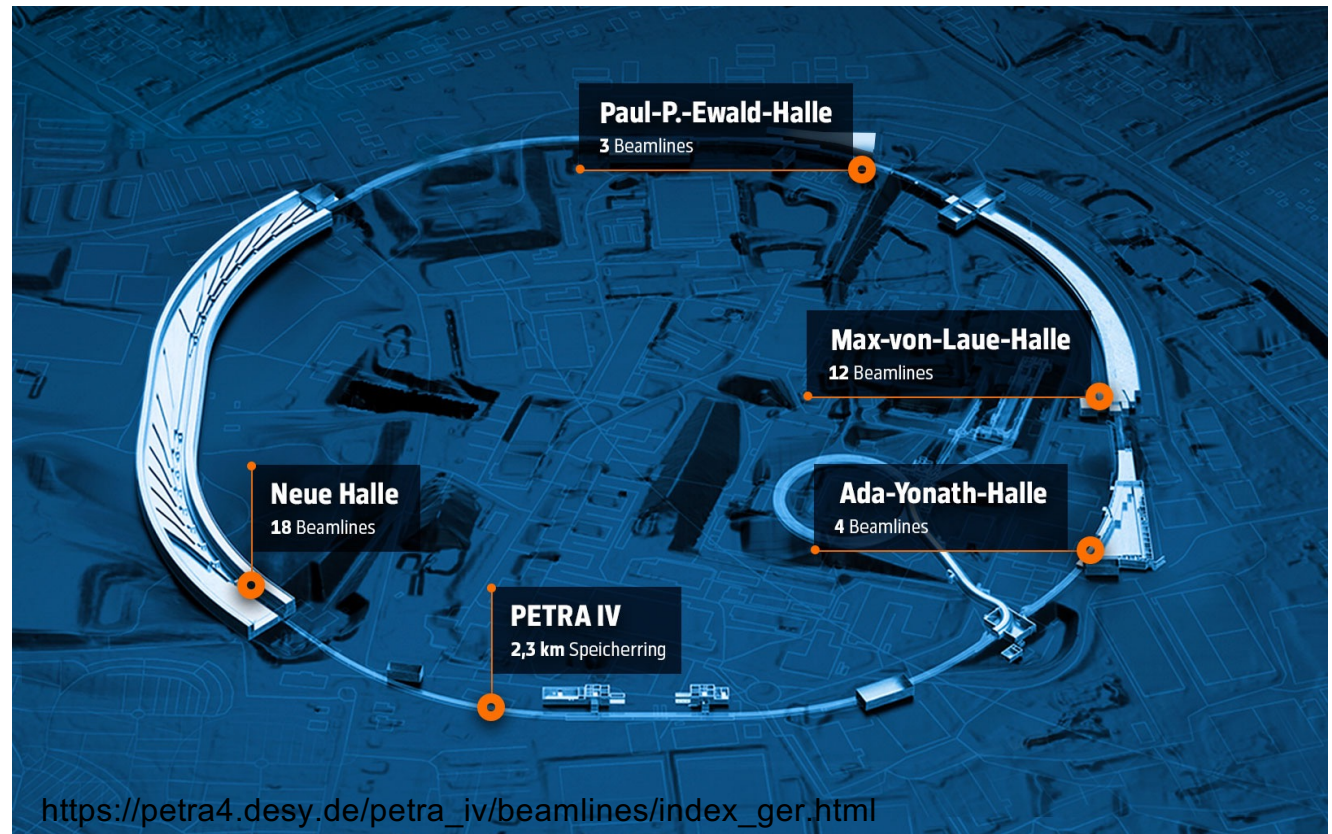

# PETRA IV

- New hard X-ray source
- PETRA III shutdown in December 2029
- PETRA IV becomes operational in 2032

## Collimators

- 8 Collimators in total
- 4 Vertical
- 4 Horizontal

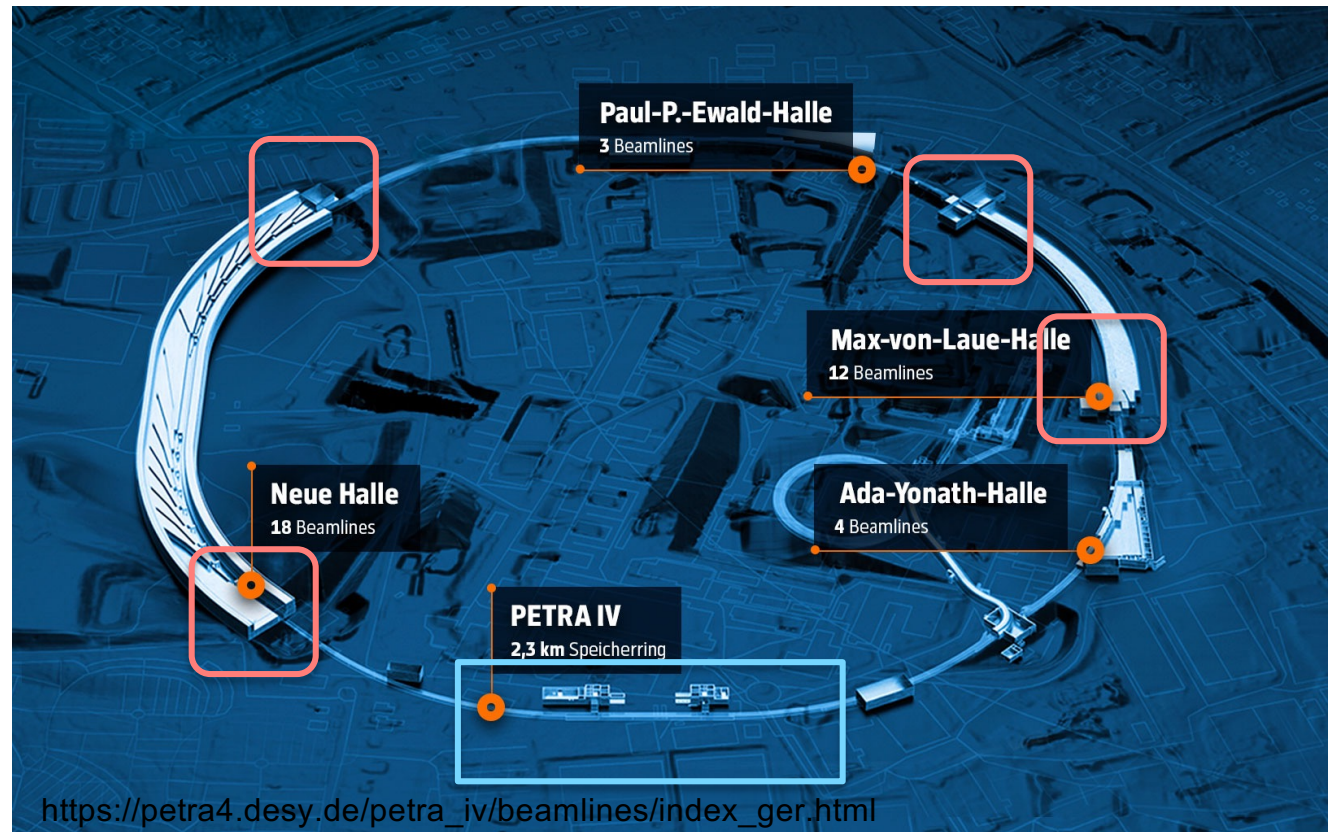

# Standard Simulation Model

- Total impedance obtained as the sum:

$$Z_{\text{total}} = Z_{\text{RW}} + Z_{\text{Geo}}$$

- $Z_{\text{RW}}$ : Resistive wall term  $\rightarrow$  material loss
- $Z_{\text{Geo}}$ : Geometrical term  $\rightarrow$  taper and shift effects
- Used three models (Mo jaw  $\rightarrow$  Tape  $\rightarrow$  full geometry) to isolate impedance sources.
- Higher-order modes (HOMs) suspected in full 3D model.

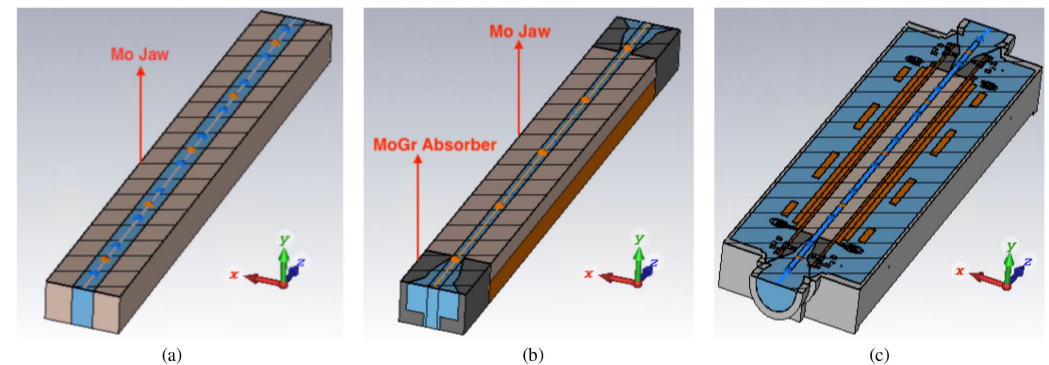
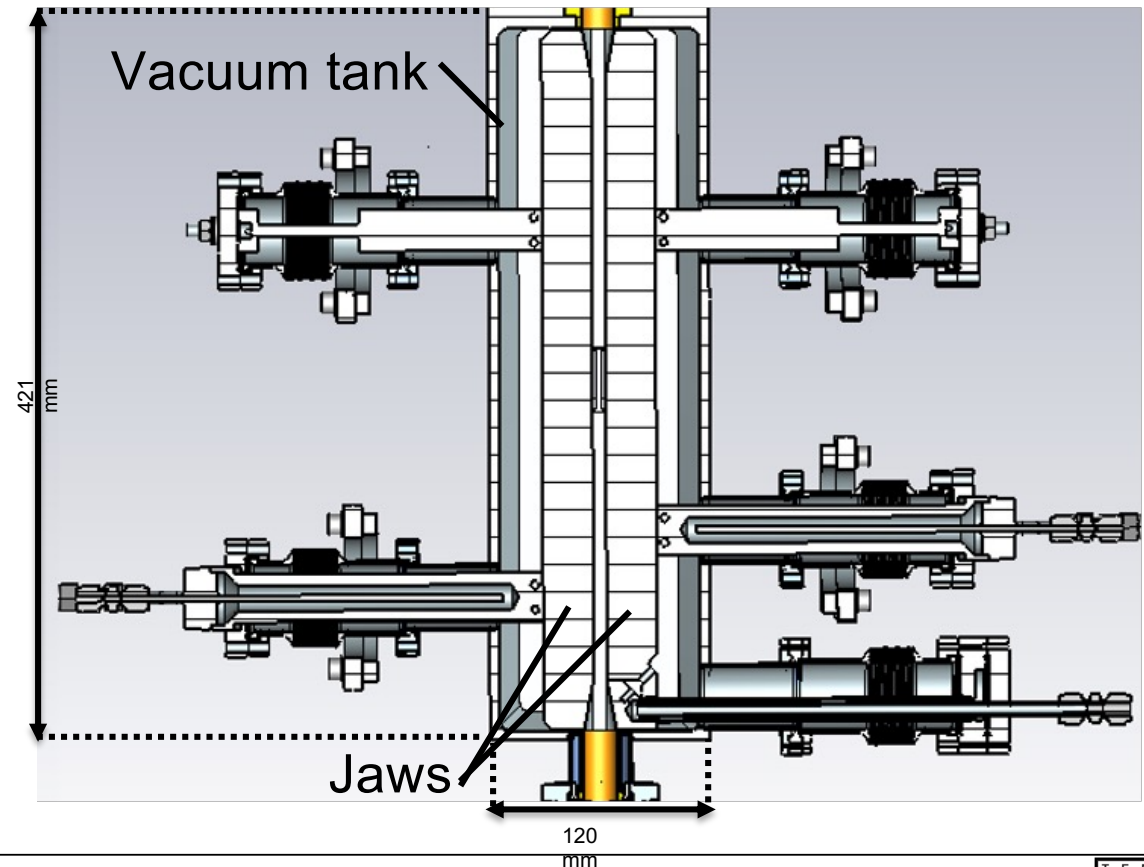

FIG. 7. Cross sections of the simulated TCSPM models. (a) Model I: the Mo jaw only. (b) Model II: both the Mo jaw and MoGr tapered absorber. (c) Model III: a more comprehensive model.

A. Kurtulus et al., “Beam-based impedance measurement of HL-LHC low-impedance collimators“, Phys. Rev. Accel. Beams, vol. 28, no. 10, p. 103001, 2025.

# Collimators - Designphase

- Estimate the impedance of the full 3D-model
- Are there trapped modes in the vacuum tank?
- Do trapped modes interfere with beam stability (and thermal stability)?



# Collimators - Designphase

- Estimate the impedance of the full 3D-model
- Are higher order modes identified?
- Do trapped modes interfere with beam stability (and thermal stability)?

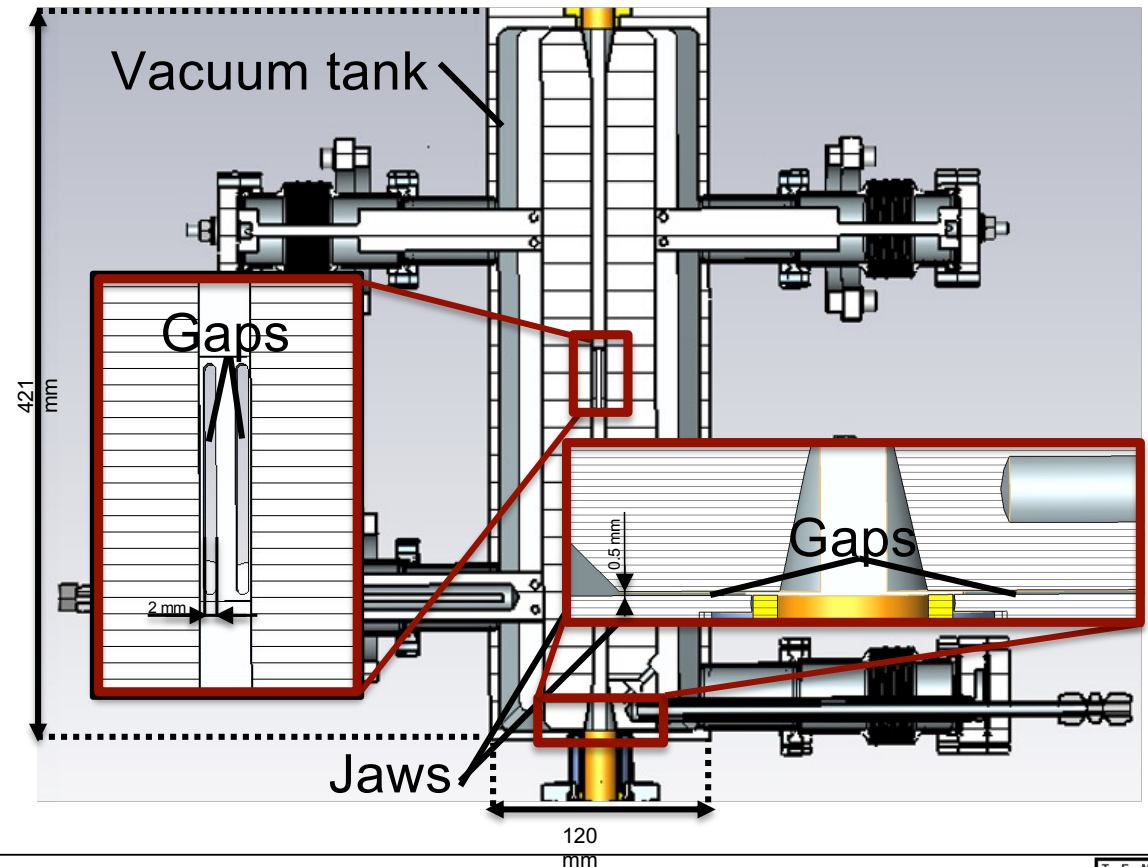

# Collimator model

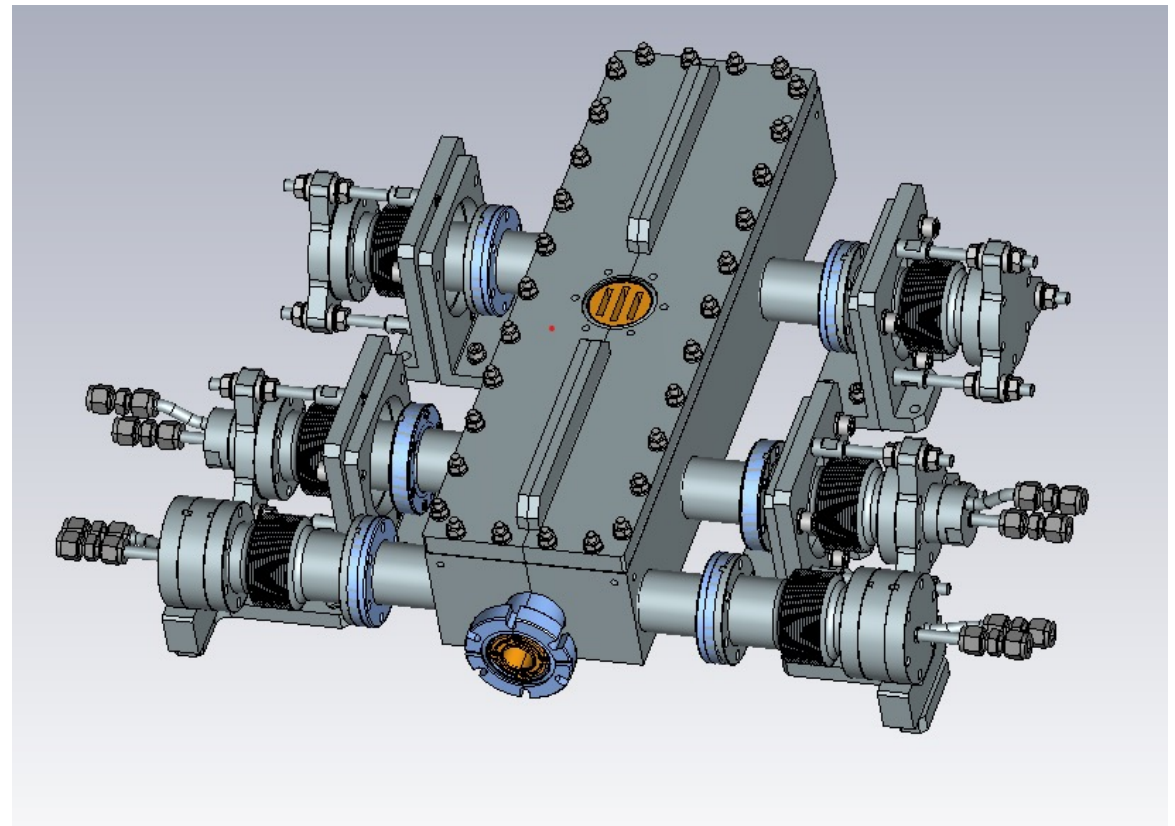
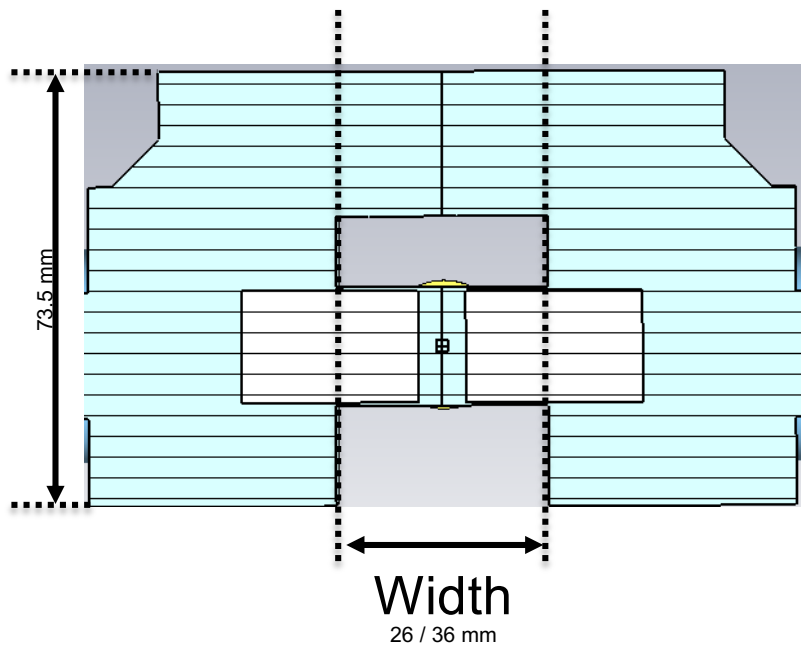

# Extracting $R_S$ and $R/Q$ from the simulations

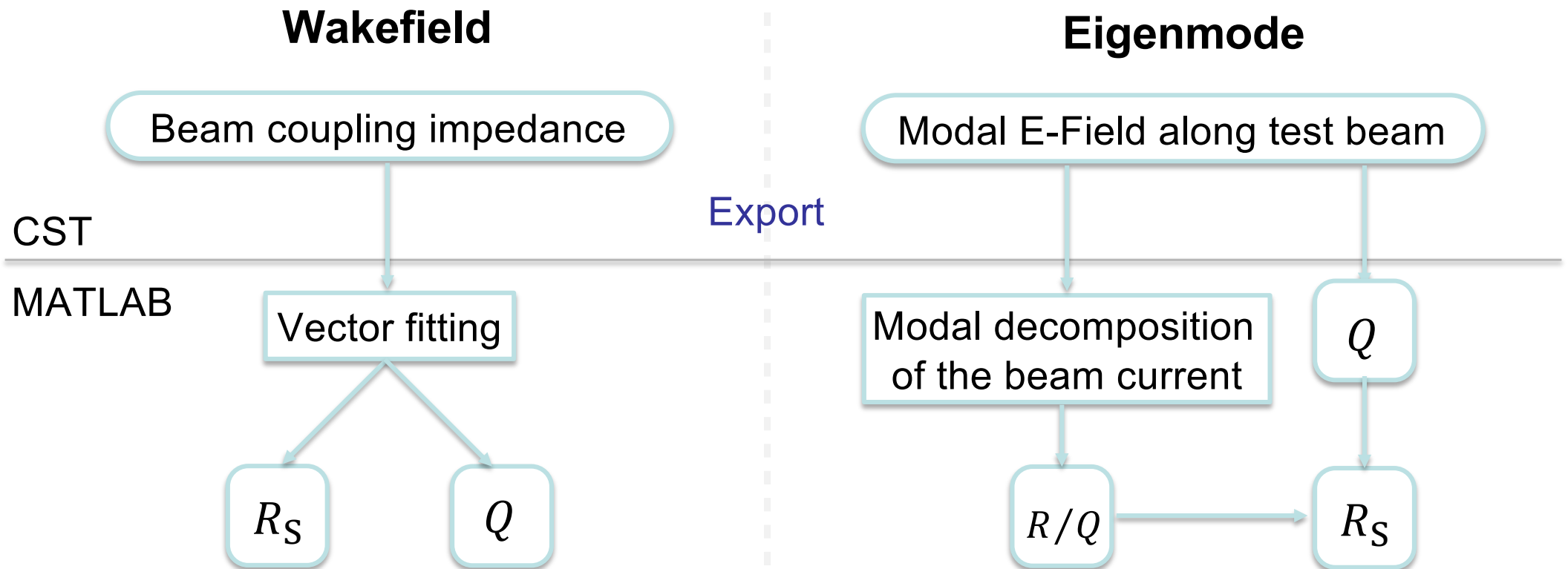

# Parameter extraction from the impedance spectrum

## Beam Coupling Impedance

$$Z(\omega) = \sum_i \frac{R_{S,i}}{1 + jQ \left( \frac{\omega}{\omega_0} + \frac{\omega_0}{\omega} \right)}$$

$Z_i$

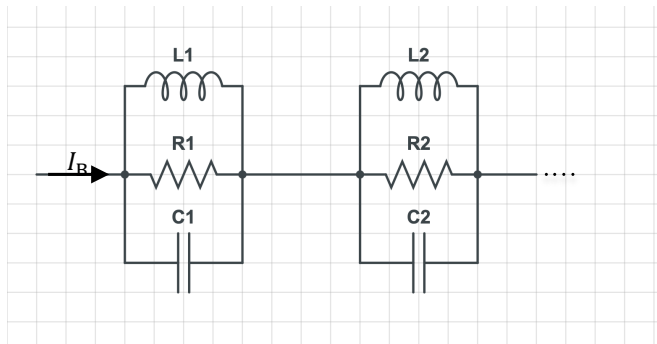

## Vector Fitting

- Common method for feature extraction from frequency domain data
- Approximates frequency response with:

$$Z(\omega) \approx \sum_k \frac{r_k}{j\omega - p_k} + d + j\omega h$$

Quetscher, F., Chae, Y.-C., Gjonaj, E., & De Gerssem, H. (2025). *Shunt impedances of the in-vacuum undulator at PETRA III* (DESY Report No. p4-WP201-rep-0019). Deutsches Elektronen-Synchrotron (DESY).  
(Report from the PETRA IV TDR-Phase)

$$Z_i(\omega) \approx \frac{\bar{r}_i}{j\omega - \bar{p}_i} + \frac{r_i}{j\omega - p_i} \quad \omega_r = \mathcal{J}\{p_i\}$$
$$R_{S,i} = -\frac{\mathcal{R}\{r_i\}}{\mathcal{R}\{p_i\}} Q = \frac{1}{2} \frac{\mathcal{J}\{p_i\}}{\mathcal{R}\{p_i\}}$$

# Shunt impedance - eigenmode solver

## Modal Expansion

$$\mathbf{E}(\mathbf{r}, \omega) = \sum_i e_i(\omega) \mathbf{E}_i(\mathbf{r})$$

$$e_i = f(\mathbf{J}_{\text{Src}}, \omega; Q, \omega_r)$$

$$= \hat{e}_i(\omega) \iiint_V \mathbf{E}_i(\mathbf{r}) \cdot \mathbf{J}_{\text{Src}} dV$$

## Beam Coupling Impedance

$$Z_{||}(\omega, \mathbf{r}_{\text{Test}}, \mathbf{r}_{\text{Src}}) = -\frac{1}{I_{\text{Src}}} \int_{-\infty}^{\infty} E_{||}(\mathbf{r}_{\text{Test}}, \omega) \exp(jkz) dz$$

$$= \sum_i \hat{e}_i(\omega) V_{i,\text{Test}}(\mathbf{r}_{\text{Test}}) V_{i,\text{Src}}(\mathbf{r}_{\text{Src}})$$

## Shunt Impedance

$$R_{s,i,||} = \text{abs} \left( Z_{||}(\mathbf{r}_{\text{Test}}, \mathbf{r}_{\text{Src}}; \omega_{r,i}) \right)$$

$$\mathbf{R}_{s,i,\perp} = \text{abs} \left( \mathbf{Z}_{\perp}(\mathbf{r}_{\text{Test}}, \mathbf{r}_{\text{Src}}; \omega_{r,i}) \right)$$

# Electric Field Energy Density in the Collimator

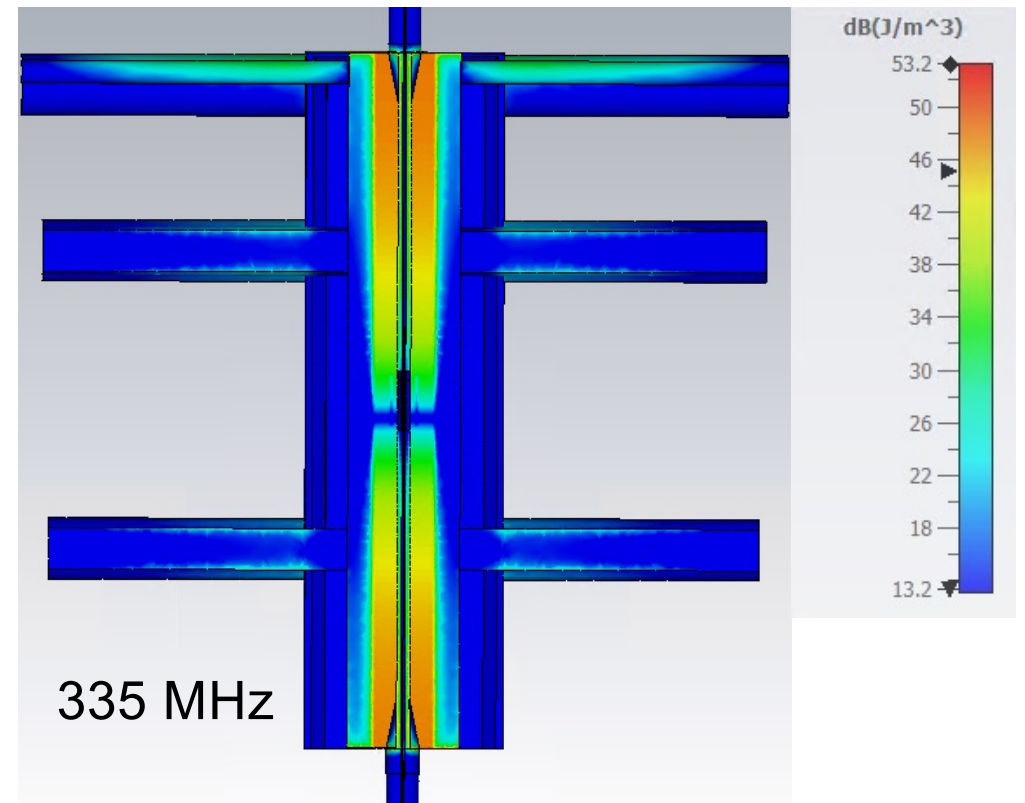
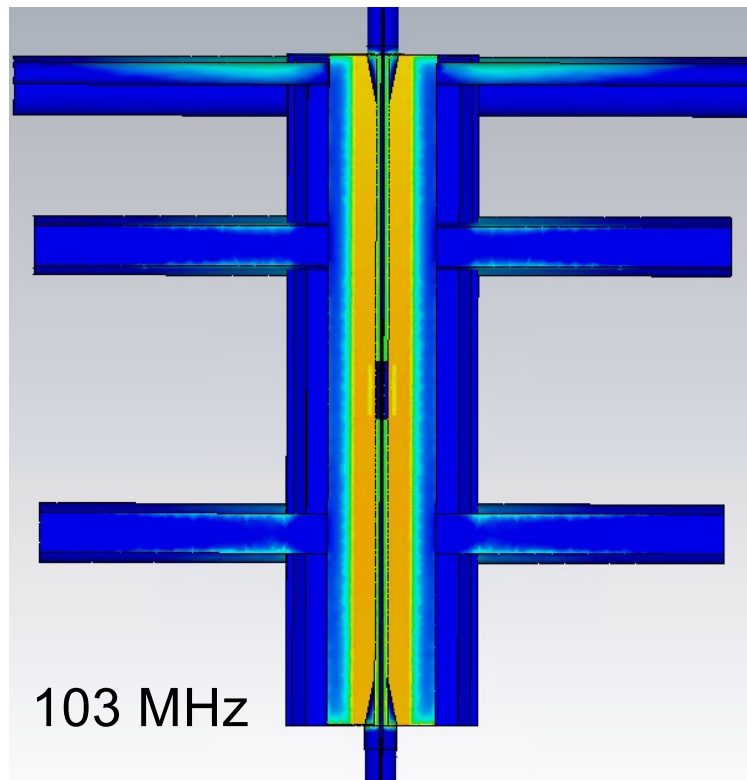

# Electric Field Energy Density in the Collimator

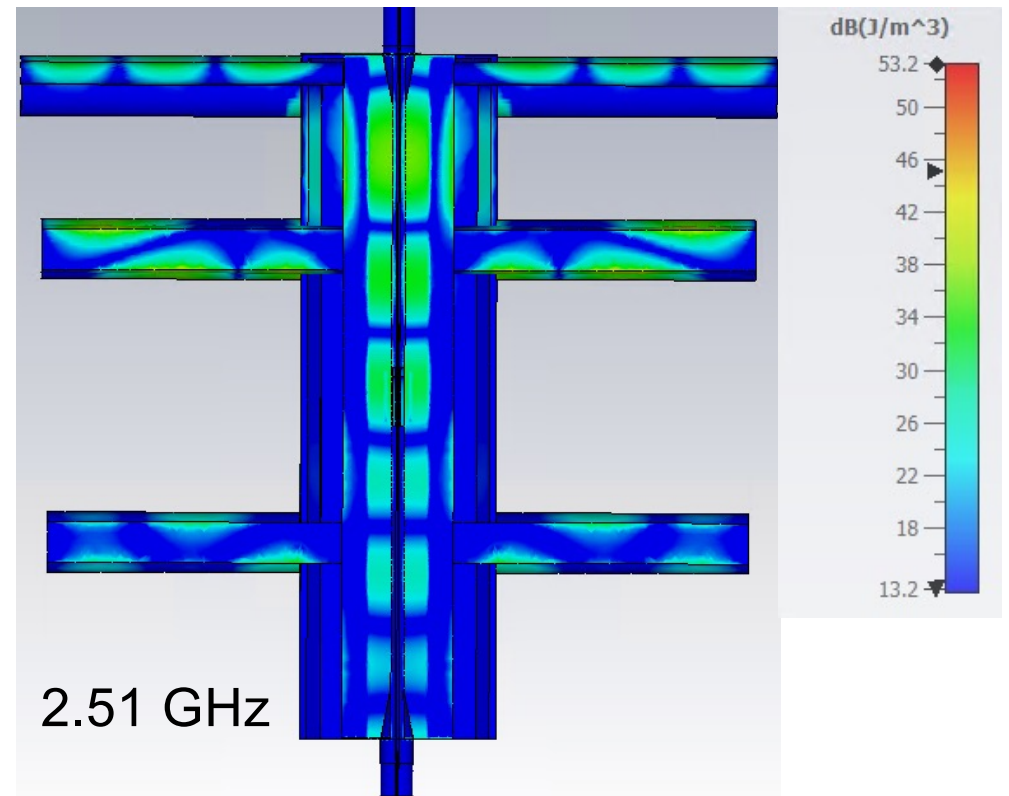
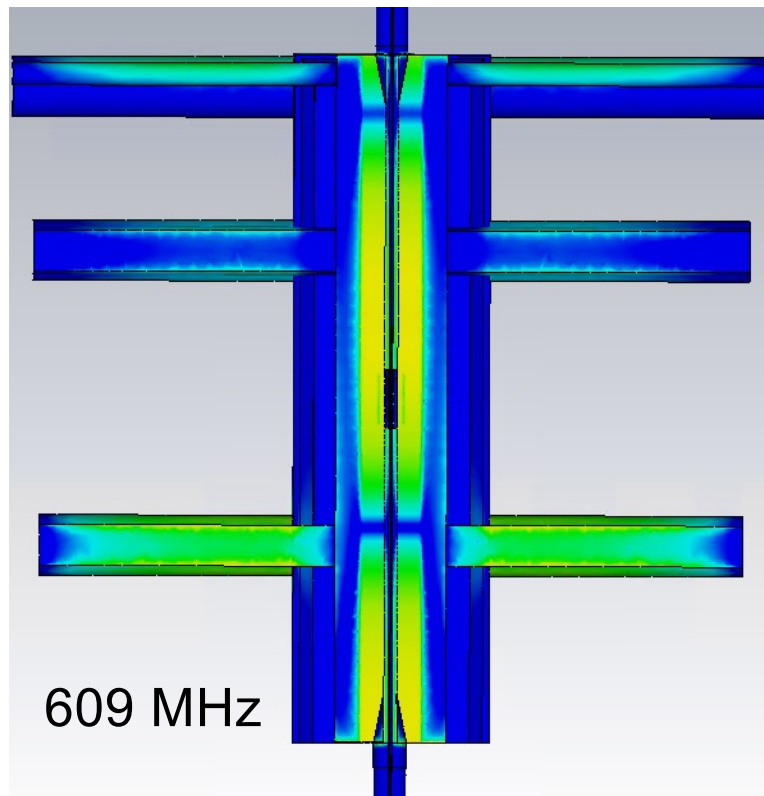

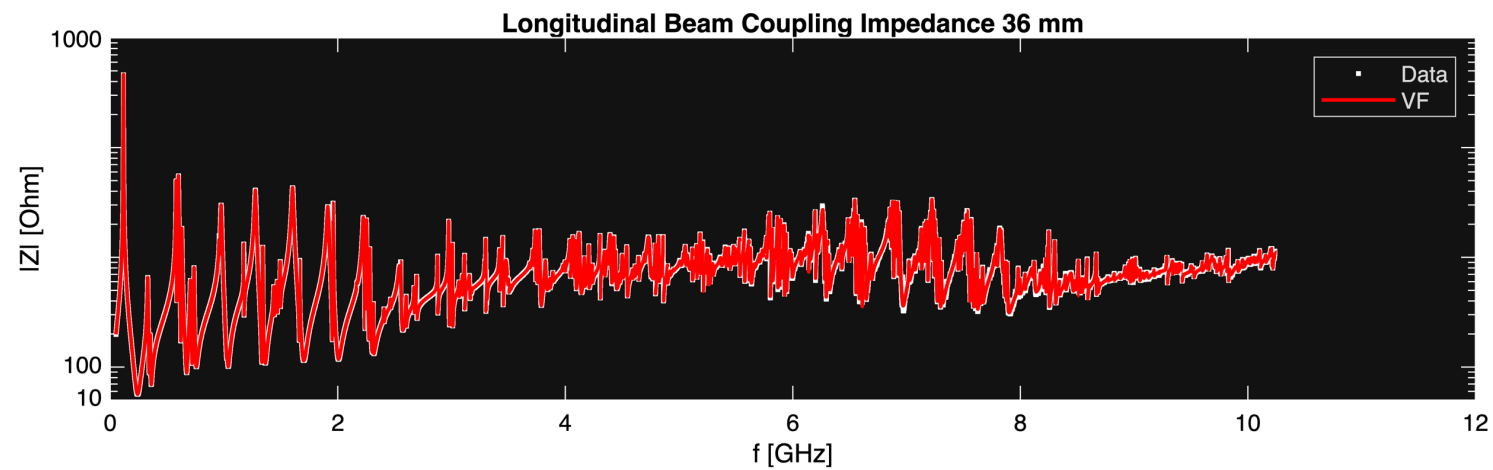
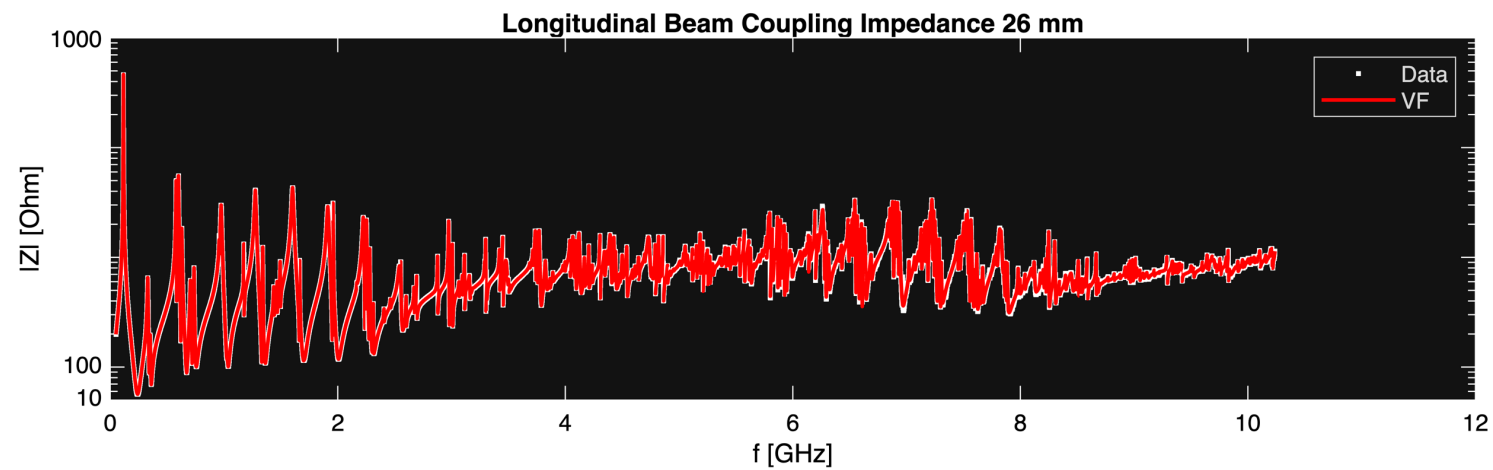

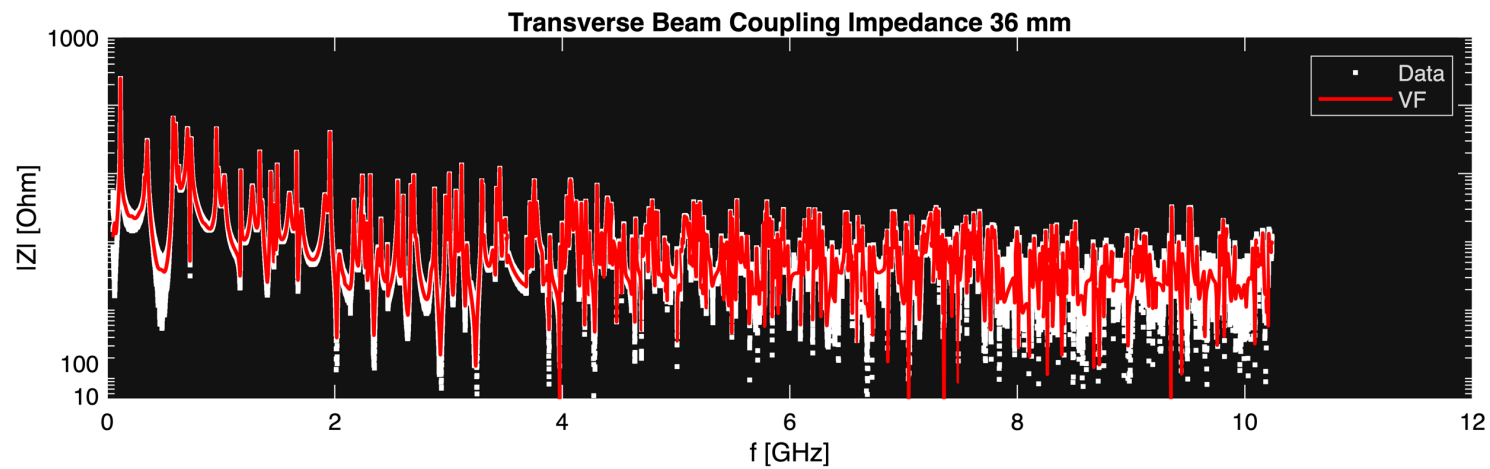
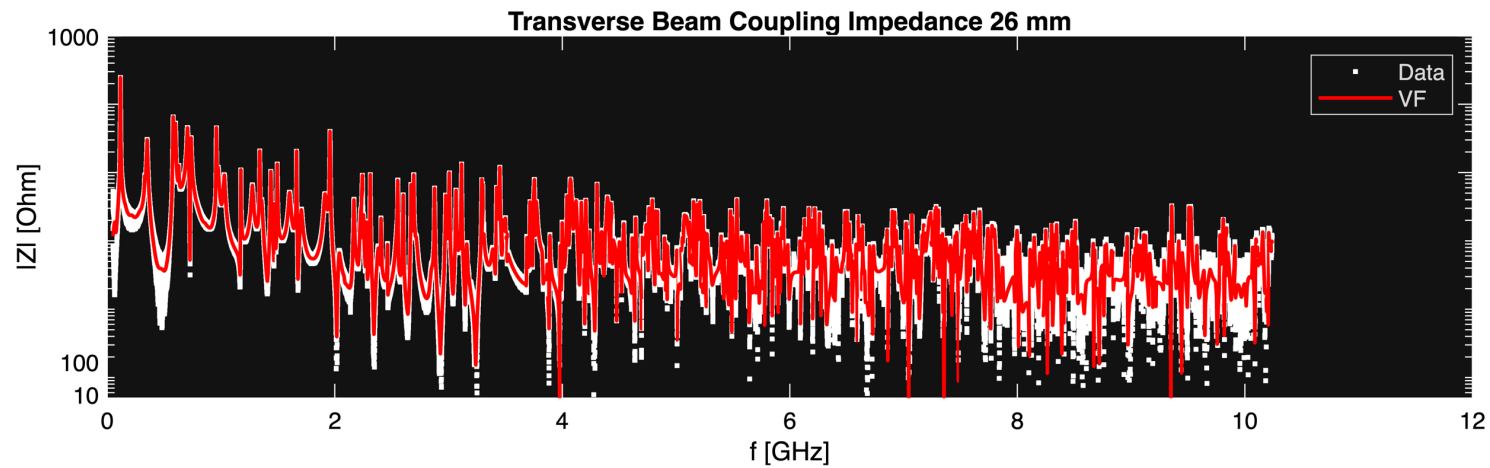

## Total Q vs Frequency

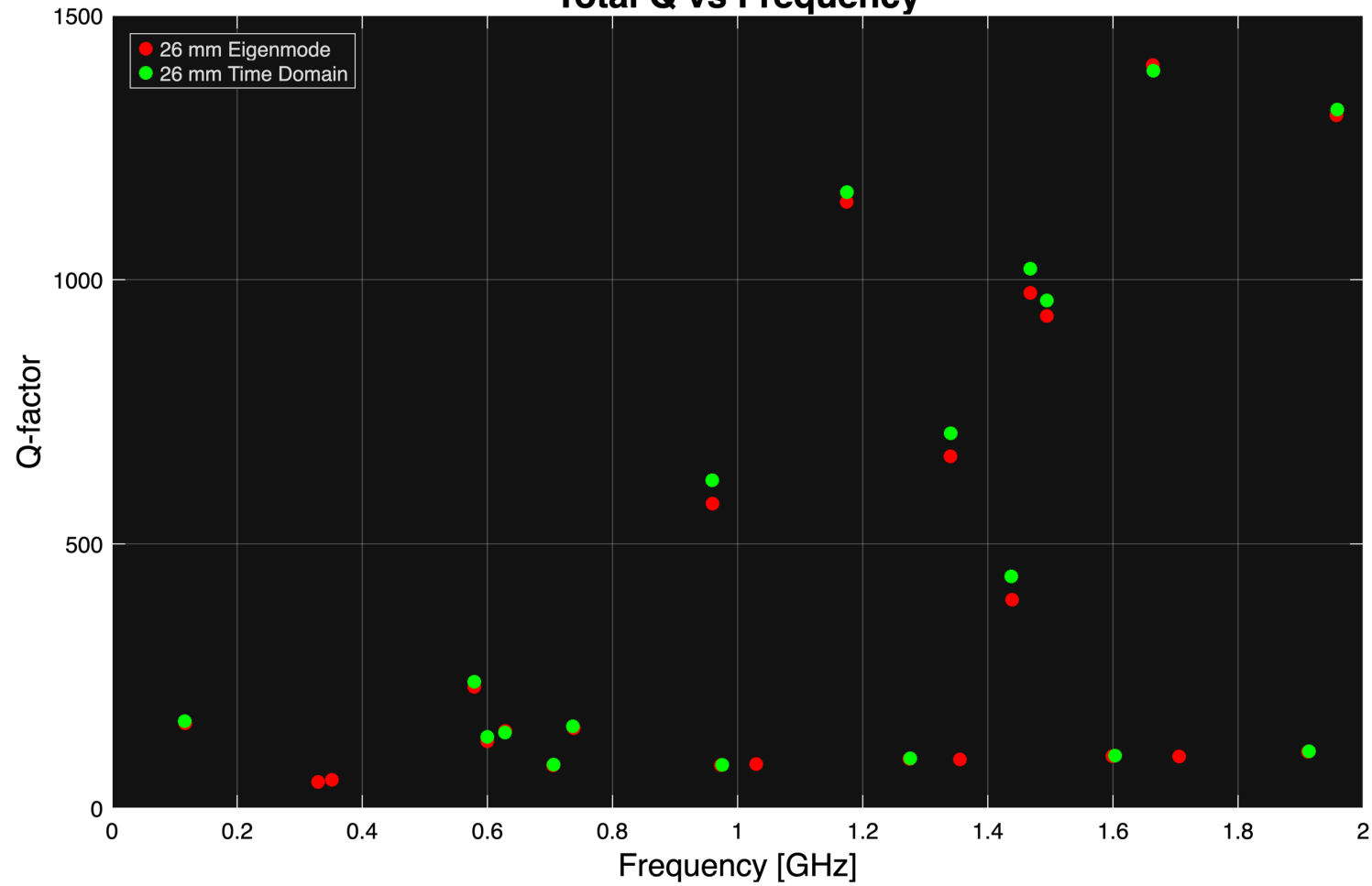

## Total Q vs Frequency

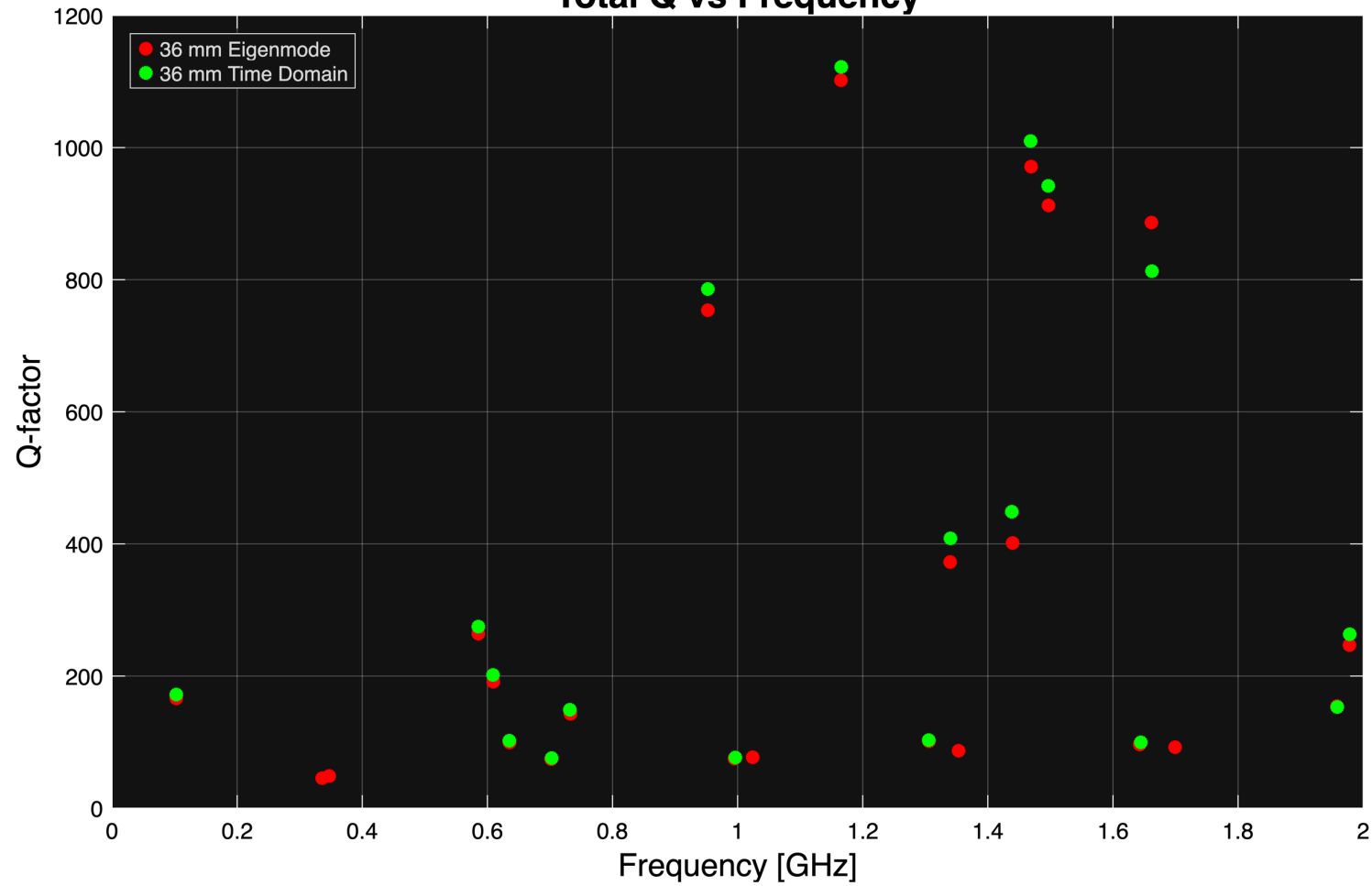

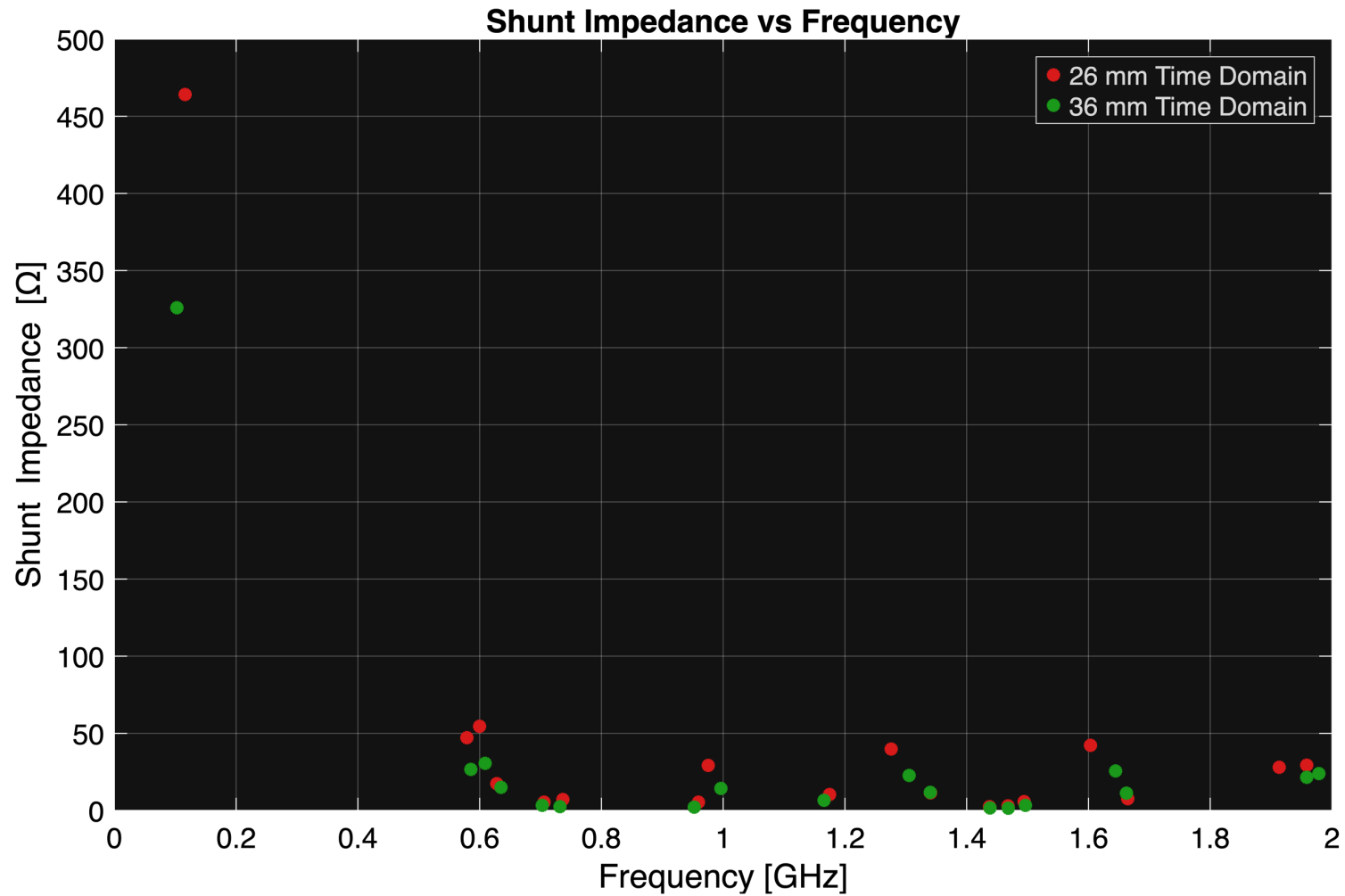

# Results

Mode (26mm)	1	2	3	4	5	6
$Q$	165.0	239.4	134.6	132.1	82.3	155.2
$f_r / \text{Mhz}$	116.2	578.8	600.0	628.1	705.7	736.6
$R / Q / \Omega$	2.813	0.197	0.405	0.132	0.066	0.046
$R_s / \Omega$	464.1	47.2	54.5	17.5	5.4	7.2

Mode (36mm)	1	2	3	4	5	6
$Q$	172.0	274.8	201.5	102.1	75.8	148.9
$f_r / \text{Mhz}$	102.7	585.4	609.0	635.0	702.8	732.0
$R / Q / \Omega$	1.849	0.097	0.152	0.147	0.044	0.017
$R_s / \Omega$	325.9	26.7	30.6	15.0	3.3	2.5

# Analytic thresholds for HOMs

Assuming all collimators have exactly the same HOMs

## Longitudinal coupled-bunch instability

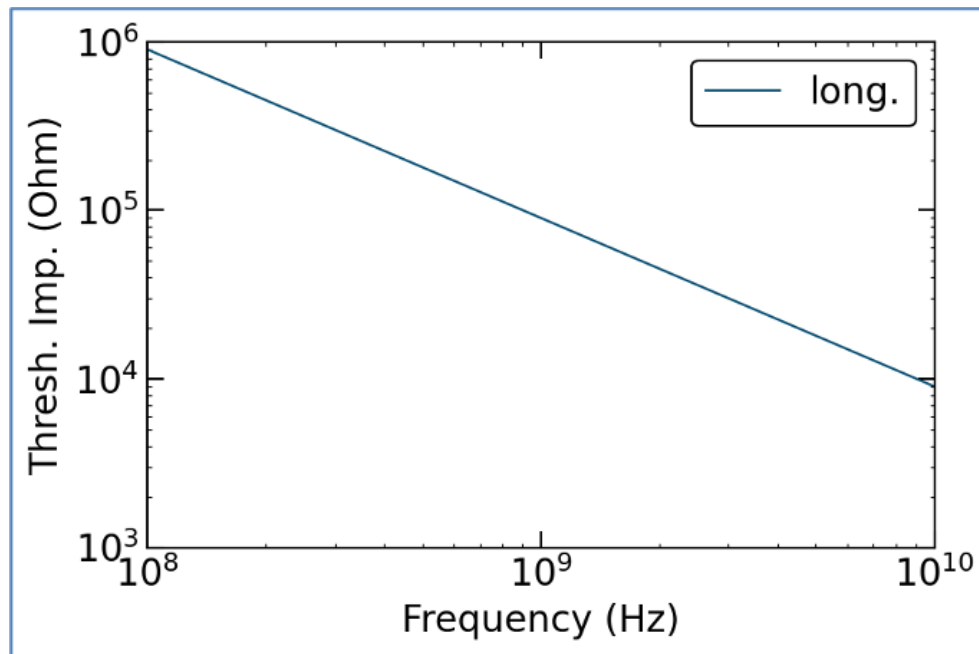

### Brightness mode

- 1920 bunches, 1 nC / bunch
- No feedback

$$Z_z^{\text{th}}(f) = \frac{1}{f} \frac{1}{N_c} \frac{2EQ}{I_b \alpha_c \tau_z}$$

# Analytic thresholds for HOMs

Assuming all collimators have exactly the same HOMs

## Transverse coupled-bunch instability

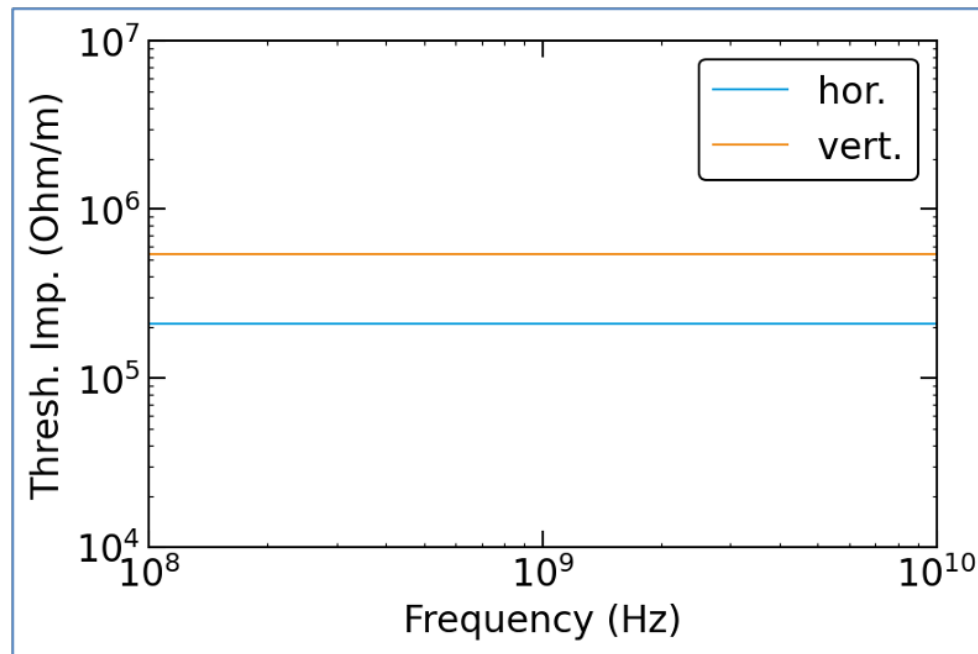

### Brightness mode

- 1920 bunches, 1 nC / bunch
- No feedback

$$Z_z^{x,y}(f) = \frac{1}{f_0} \frac{1}{N_c} \frac{2E}{I_b \beta_{x,y} \tau_{x,y}}$$

# Transverse modes can be damped by feedback of chromaticity

Thanks to their low frequency. Example: HOM at 180 MHz

## Chromaticity 0

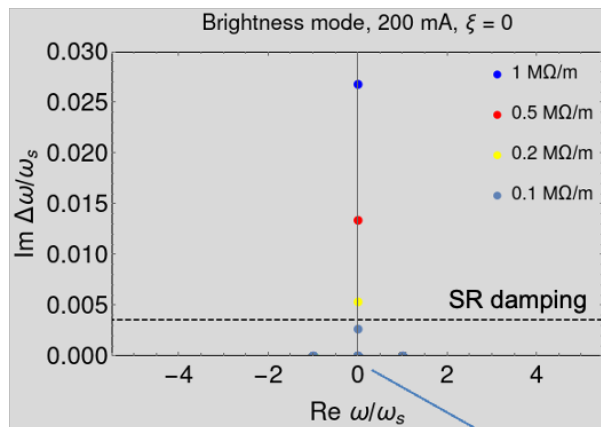

## Chromaticity 1

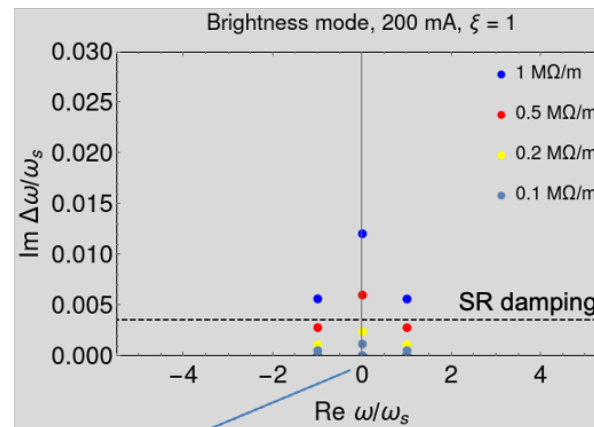

## Brightness mode

- 1920 bunches, 1 nC / bunch

- No feedback

## Simulation in Nested Head-Tail (NHT) Vlasov solver

- HOM as the sole source of impedance

- Vertical collimator (90 deg rotation)

**Mode 0** (dipole mode) can be readily damped by the coupled-bunch feedback

# Transverse modes can be damped by feedback of chromaticity

Thanks to their low frequency. Example: HOM at 180 MHz

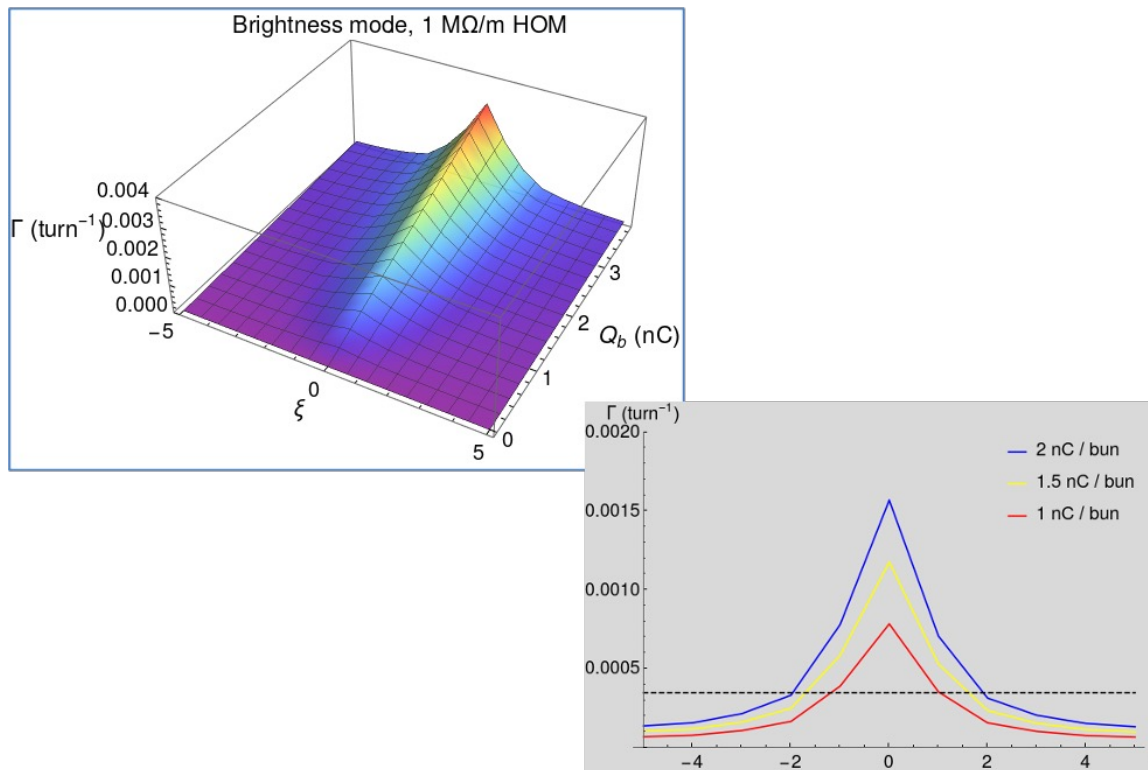

## Brightness mode

- 1920 bunches, 1 nC / bunch
- No feedback

## Simulation in Nested Head-Tail (NHT) Vlasov solver

- HOM as the sole source of impedance
- Vertical collimator (90 deg rotation)

---

# Conclusion

- **Standard simulation approach not conclusive**
- **Strong influence of HOMs**
- **Full 3D simulations remain essential**
- **Modal analysis enables clear identification of dominant HOMs**